

# aumüller

## Assembly and Commissioning Instructions

according to Machinery Directive 2006/42/EC (annex VI)



KS4 S12 24V DC - CHAIN DRIVE FOR WINDOWS **CE**

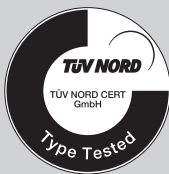

01	<p>Abbreviations            Target Groups            Warning and Safety Symbols            Intended Use            Safety Instructions</p>	3 - 8
02	<p>Data sheet KS4 S12 24V DC R            Data sheet KS4 S12 24V DC L            Explanations on the product label</p>	9 - 12
03	<p>Growing variants and minimum casement dimensions</p>	13
04	<p>INSTALLATION STEP 1: Inspection before the installation            INSTALLATION STEP 2: Installation prerequisite and Installation preparation</p>	14 - 15
05	<p>INSTALLATION STEP 3: Dimensions and hole layouts: casement brackets and frame brackets            INSTALLATION STEP 4: Hole layout for frame bracket and casement bracket (top-hung / buttom-hung)            INSTALLATION STEP 5: Additional order (side-hung)            INSTALLATION STEP 6: Hole layout for frame bracket and casement bracket (Tandem)</p>	16 - 21
06	<p>INSTALLATION STEP 7: Drill holes according to mounting variants            INSTALLATION STEP 8A: Swiveling drive mounting on the window frame            INSTALLATION STEP 8B: Rigid drive mounting on the window frame (inward opening windows)            INSTALLATION STEP 8C: Rigid drive mounting on the casement (inward opening windows)            INSTALLATION STEP 8D: Rigid drive mounting on the window frame (outward opening windows)</p>	22 - 26
07	<p>INSTALLATION STEP 9: Cable routing            INSTALLATION STEP 10: Electric Connection            INSTALLATION STEP 11: Supply lines of the Control Unit to the drives            INSTALLATION STEP 12: Soft run mode            INSTALLATION STEP 13: Safety check and Test run</p>	27 - 32
08	<p>Removal and Disposal            Liability            Warranty and After-Sales Service</p>	33 - 35

## Abbreviations

Index of abbreviations	
These abbreviations are used consistently throughout these assembly & operating instructions. Unless stated differently, all dimensions indicated in this document are in mm. General tolerances in accordance with DIN ISO 2768-m.	
A	drive
AK	connection cable / drive cable
AP	cover cap
BD	hinge
Fxxx	casement bracket
FAB	overall width of casement
FAH	overall height of casement
FG	casement weight
FL	casement
FÜ	casement overlap
HSK	main closing edge
Kxxx	frame bracket
L	construction length of drive
MB	central hinge
NRWG	NSHEV – natural smoke and heat exhaust ventilation
NSK	side closing edge
RA	frame
RAB	overall width of frame
RAH	overall height of frame
RWA	SHEV – smoke and heat exhaust ventilation
SL	snow load
→	opening direction

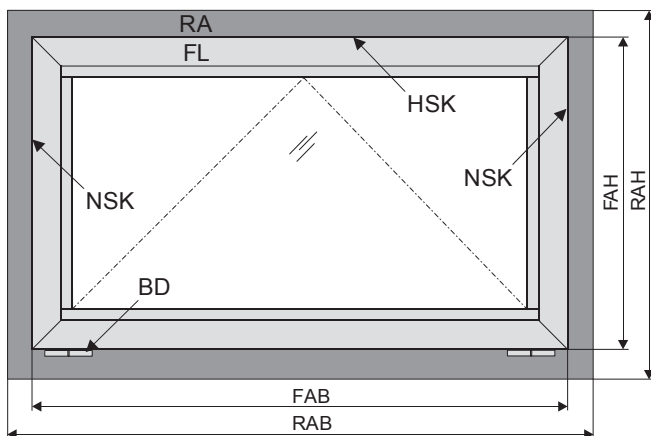







## Target group

These instructions are intended for trained personnel and operators of systems for natural smoke ventilation (NRA / RWA) (natural smoke exhaust system / smoke and heat exhaust system) and natural ventilation via windows, who are knowledgeable of operating modes as well as the remaining risks of the system.

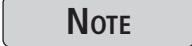
## Warning and safety symbols in these Instructions:

The symbols used in the instructions shall be strictly observed and have the following meaning:

-  **DANGER** Failure to comply with the warning notes results in irreversible injuries or death.
-  **WARNING** Failure to comply with the warning notes can result in irreversible injuries or death.
-  **CAUTION** Failure to comply with the warning notes can result in minor or moderate (reversible) injuries.
-  **NOTE** Failure to comply with the warning notes can lead to damage to property.

-  **Caution / Warning**  
Danger due to electric current.
-  **Caution / Warning**  
Risk of crushing and entrapment during device operation (is provided as a sticker with the drive).
-  **Attention / Warning**  
Risk of damage to / destruction of drives and / or windows.

 **WARNING** Once the assembly and commissioning has been completed, the installer of a machine „power-operated window and door“ shall hand these instructions over to the end-user. The end-user shall store these instructions in a safe place for further reference and use, if required.

 **WARNING** This device is not intended for use by persons (including children) with physical, sensory or mental limitations or lacking experience and / or knowledge, unless they are supervised by a person who is responsible for the safety or were instructed by him on the usage of this equipment. Children should be supervised to ensure that they are not playing with this device. Cleaning and operator's maintenance may not be performed by children without supervision.

## Intended use

### Area of application / Scope of application

This drive is intended for the electromotive opening and closing of windows in facade and roof areas.

**The main task of this product**, in combination with a window and a suitable external control unit, **is to evacuate hot smoke and combustion gases in case of fire**, to save human lives and protect material assets. Furthermore, with the electromotive operated window and a suitable external control unit, **the natural ventilation** of the building can be ensured.

#### NOTE

By attaching the drive to a movable element of the window a so-called "power-operated window" is created which, according to the Machinery Directive 2006 / 42 / EG, represents a machine.

### Intended use according

The drive is intended for stationary installation and electrical connection at the window as part of a building.

The drive is in combination with an external Control Unit (e.g. from **AUMÜLLER**) released for its proper use at a power-operated window for the following use:

- Application for natural ventilation
  - with an installation height of the drive and the bottom side of sash of at least 2,5 m above the floor, **or**
  - with an opening width at the HSK of the driven part of < 200 mm by a simultaneous speed of < 15 mm/s at the HSK in closing direction.
- Application as NRWG (natural smoke and heat exhaust ventilator(s) for ventilation without dual purpose for ventilation in accordance with EN12101-2.

Pay attention to possible hazards on tilting or rotating windows, whose secondary closing edges are located at less than 2,5 m installation height above the floor, under consideration of the Control Unit and usage!

#### WARNING

We as manufacturers are well aware of our duties and responsibilities regarding the development, manufacturing and placing of safe window drives on the market and consistently implement them. Ultimately, however, we have no direct influence on the usage of our drives. Therefore, as a precaution, we point out the following:

- The **constructor or his agent** (architect, specialist planner) **are obligated to evaluate the hazards to persons**, outgoing from the usage, installation position, opening parameters and from the external Control Unit of the power operated window, **already in the planning phase and to establish necessary protective measures.**
- The **constructor / manufacturer** of the machine "power-operated window" **must implement the planned protective measures** at the installation site or, if not yet established, **determine them** by it's own responsibility and detect or **minimize possible remaining risks.**

### The need for a risk assessment at the installation site due to the reasonably foreseeable misuse.

**A risk assessment in accordance with the Machinery Directive 2006 / 42 / EG for the usage of the power-operated window for natural ventilation is absolutely necessary** under the following conditions:

- the installation height of the drive and lower edge of casement < 2,5 m above the floor **and** one of the following conditions:
- the opening width at the HSK > 200 mm, **or**
- the closing speed at the HSK is > 15 mm/s, **or**
- the opening speed at the HSK is > 50 mm/s, **or**
- the closing force at the HSK is > 150 N

The following flow chart can be applied, which also includes the protective measures in accordance with EN 60335-2-103/2016-05.

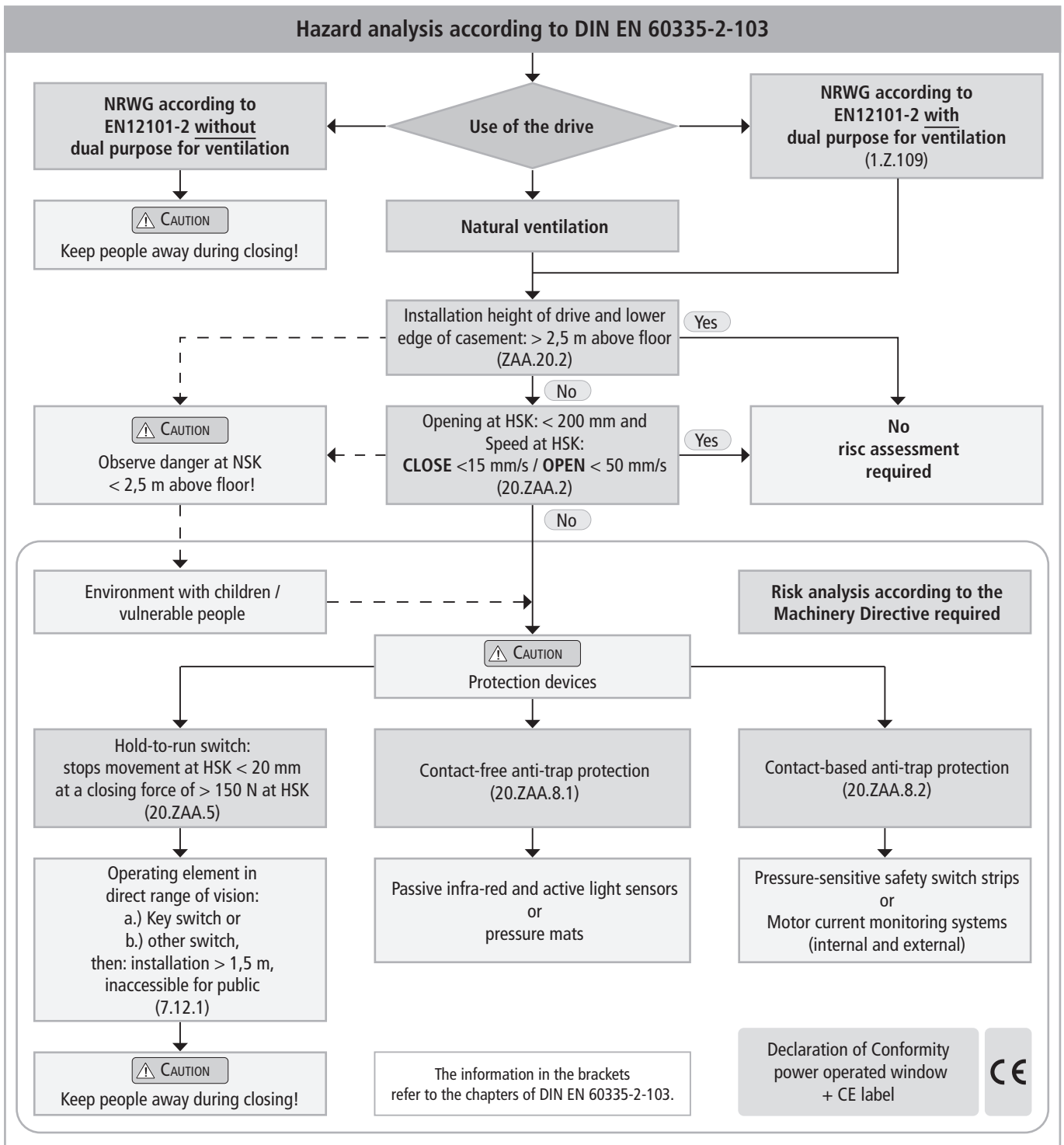

**Casement data**

Facade: bottom-hung window / top-hung window / side hung window  
 Roof: roof window / sky light  
 Opening direction: inward opening / outward opening  
 Profile material: aluminum, steel, plastic or wood.

The casement measurements supplied are only for orientation purposes. It is imperative that the **force-path diagram** of the drives are observed.

**NOTE**

When inspecting the drives for conformity with on-site requirements the following items must be observed:

- total weight of casement (glass + frame),
- additional loads: snow load / wind load (suction / pressure),
- casement size (FAB x FAH),
- side ratio FAB / FAH,
- installation / inclination angle,
- required opening area (geometric / aerodynamic),
- crosswind influences,
- driving force and stroke,
- mounting space at the window frame and casement frame.

## Safety instructions



It is important to follow these instructions for the safety of persons. These instructions shall be kept in a safe place for the entire service life of the products.

### Risk of crushing and entrapment! Window can close automatically!

The integrated load cut-off stops the drive during closing and opening when the drive is overloaded.

**The compressive force is absolutely sufficient to crush fingers in case of carelessness.**



### Area of application

The drive shall only be used according to its intended use. For additional applications consult the manufacturer or his authorized dealer.

Do not misuse the drive for other lifting operations!



Do not allow children to play with this drive or its electric controls, including the remote control!

Always check whether the system complies with current regulations. Special attention must be paid to the opening width, the opening area, the opening time and the opening speed of the window, the temperature range of the drives / external devices and cables as well as the cross section of the connecting cables as function of the cable length and power consumption.



All devices must be permanently protected from dirt and moisture, if the drive is not explicitly suitable for use in wet areas (see technical data).

### Installation

These instructions address expert and safety-conscious electricians and / or qualified personnel knowledgeable in electrical and mechanical drive installation.



The safe operation, avoidance of injury to persons and damage to property, as well as risks, is only guaranteed by proper installation and setting according to these installation instructions.

All specifications for installation must be checked independently and, if necessary, adjusted at the installation site. The connection assignment, the electrical supply data (see product label) and performance limits (see technical data) as well as the mounting and installation instructions of the drive must be strictly observed and adhered to!



Never connect 24 V DC drives to 230 V AC mains voltage!  
**Danger to life!**

Do not reach into the window rabbet or the operating element (chain or spindle) during installation and operation! Ensure that, based on the installation position and the opening movement of the casement, persons cannot be trapped between the driven part of the window and surrounding fixed components (e.g. wall).

### Mounting material

The required mounting material must fit with the drive and occurring load and, if necessary, supplemented.



Before installing the drive, check whether the casement is in good mechanical condition, the weight in balance and whether it opens and closes easily!

### Danger spots by crush and shear points

<p>Side-hung</p>	<p>Bottom-hung</p>	<p>Roof windows / skylight domes</p>	<p>Louvre windows</p>
<p> Danger spots: crush and shear points according to DIN EN 60335-2-103</p>			

### Crush and shear points

To avoid injuries, **crushing and shear points** between casement and frame must be secured **against entrapment up to an installation height of 2,5 meters above the floor** with appropriate measures. This can be achieved e.g. by using contact-based or contactless protective devices against entrapment, which stop the motion through contact or through interruption by a person. At a force higher than 150 N at the main closing edge the motion must stop within 20 mm. A warning symbol at the opening element must indicate this clearly.

### Unintentional or independent opening or falling

Casements are to be hinged or secured such way that in case one of the mounting elements fails it will not crash / slam down or move in an uncontrolled manner by e.g. using double suspensions, safety scissors, casement stays. Tilting windows shall be equipped with safety scissors or similar devices to avoid damages and risks of injury for persons through improper installation and operation. The safety scissors must be adjusted to the opening stroke of the drive (see technical data) to avoid blocking. The opening width of the safety scissors must be bigger than the drive stroke.



**WARNING**

The movable casement must be secured against unintentional or independent opening as well as falling down.

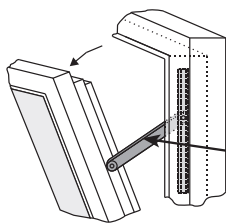

safety scissors

### Routing cables and electrical connection

Routing or installing of electrical cables and connections may be performed only by specialist companies. Never operate drives, control units, operating elements and sensors at operating voltages and connections contrary to the specifications of the manufacturer. All relevant national instructions shall be observed for the installation.



All-pole disconnecting devices shall be installed in the permanent electrical installation or external Control Unit for the drive. The mains supply lines 230 V / 400 V AC shall be protected separately!



24V DC drives may only be connected to power supply sources that comply with SELV specifications.

**NOTE**

In the case of tandem / multiple operation of drives connected in series, the cross-section of the connection cable must be checked autonomously, depending on the total current consumption of the drive system.



**WARNING**

Damaged mains supply lines of drives with plug connectors may only be replaced by the manufacturer or qualified service / maintenance personnel! Power cables which are fixed to the drive casing cannot be replaced. If the cable is damaged the device must be scrapped!

The types of cable, cable lengths and cross-sections shall be selected in accordance with the manufacturer's technical data. If necessary, the cable types shall be coordinated with the competent local authorities and energy supply companies. Low-voltage lines (24 V DC) shall be routed separate from the high-voltage lines. Flexible cables may not be flush-mounted. Freely suspended cables shall be equipped with strain reliefs.



Cables must be laid such way that they cannot be sheared off, twisted or bent during operation. Drive cables laid inside window profiles must be protected by insulating tubes with a sufficient temperature resistance. Through holes shall be equipped with cable sleeves!

Clamping points shall be checked for tightness of threaded connections and cable ends. Access to junction boxes, clamping points and external drive control boxes shall be ensured for maintenance work.



**Commissioning, operation and maintenance**

After the installation and after each modification in the set up all functions shall be checked with a trial run. It shall be ensured that drive and casement are set correctly and that security systems, if available, are functioning properly.

**After the installation of the system is completed the end-user shall be instructed in all important operating steps.** If necessary, he must be advised of all remaining risks / dangers.

The end-user shall be specifically instructed that no additional forces, except pushing and pulling forces in the opening and closing direction of the casement, may be applied to the spindle, chain or lever of the drive.

**NOTE** Post warning signs!

During the proper assembly of drives with mounting elements at a window, and the connection to an external control unit, the interfaces resulting from mechanical and electrical performance characteristics of single elements shall be observed.

Other persons must be kept away from the casement when a hold-to-run switch (pushbutton) is operated or when a window, which has been opened by a smoke and heat exhaust system, is closing!

 **CAUTION**

The operating element of hold-to-run switches must be installed within direct view from the window, but apart from moving elements. If the switch is not a key-operated switch it must be installed at a minimum height of 1,5 m and inaccessible to the public!

 **CAUTION**

Do not allow children to play with permanently mounted control devices and keep remote controls out of reach for children!

 **CAUTION**



During cleaning, maintenance work and while exchanging parts the drive must be completely disconnected from the power supply and secured against unintentional reactivation.

 **WARNING**

Do not actuate the drive or the casement when repair or re-setting works are performed!

**Replacement parts, fasteners and controls**

The drive shall only be operated with control devices from the same manufacturer. There is no liability, warranty or customer service if third-party parts are used. Exclusively original spare parts of the manufacturer shall be used for mounting elements or expansions.

**Ambient conditions**

The product may not be subjected to impacts or falls, or to vibrations, moisture, aggressive vapors or other harmful environments, unless the manufacturer released it for one or more of these environmental conditions.

- **Operation:**  
 Ambient temperature: -5 °C ... +60°C  
 Relative humidity: < 90% less 20°C;  
 < 50% less 40°C;  
 no formation of condensation

**NOTE** Observe temperature range during installation!

We recommend the use of wind and rain sensors in order to avoid weather-related damages to drives, windows and buildings thru open window sashes.

**NOTE**

- **Transport / Storage:**  
 Storage temperature: -5°C ... +40°C  
 Relative humidity: < 60%

**Accident prevention regulations and workmen's compensation insurance guidelines**

For work on or in a building or building part the provisions and instructions of the respective accident prevention regulations (local workmen's compensation insurance guidelines) shall be observed and adhered to.

**Declaration of Conformity and of Incorporation**

The drive is manufactured and inspected in accordance with European guidelines. The respective Declaration of Conformity and of Incorporation is on hand.

**In case that the use of the drive differs from the intended use, a risk evaluation for the power operated window shall be performed and a Declaration of Conformity according Machinery Directive 2006 / 42 / EG issued.**



## Data sheet KS4 S12 24V DC R

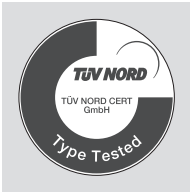

- Application: natural ventilation, RWA, ferralux®-NRWG
- Internal intelligent cut-off switch S12
- Feedback limit position „CLOSE“ (max. 24V, 500 mA)

*Equipment:*

- Additional **AUMÜLLER-Click plug set** for multi-drive operation

*Options:*

- Programmable special functions
- Programmable feedback limit position „OPEN“ (max. 24V, 500 mA)
- M-COM for automatic synchronised run of multi drive systems and automatic sequence control with locking drives (S3 / S12)

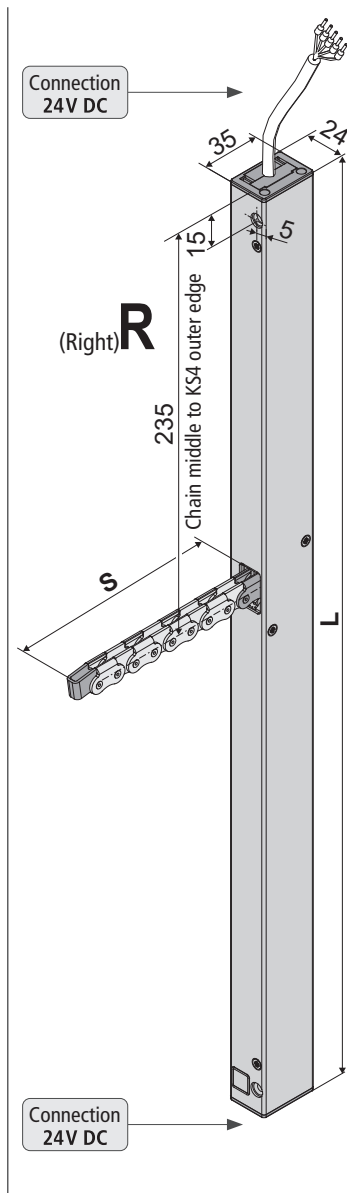
**Technical Data**

$U_N$	Rated voltage	24V DC (19 V ... 28 V)
$I_N$	Rated current	0,9 A
$I_A$	Cut-off current	1,2 A
$P_N$	Rated power	22 W
DC	Duty cycle	5 cycles (ED 30 % - ON: 3 min. / OFF: 7 min.)

	Protection rating	IP 32
	Ambient temperature range	-5 °C ... +60 °C

$F_Z$	Pulling force max.	400 N
-------	--------------------	-------

$F_A$	Pushing force max.	
-------	--------------------	--

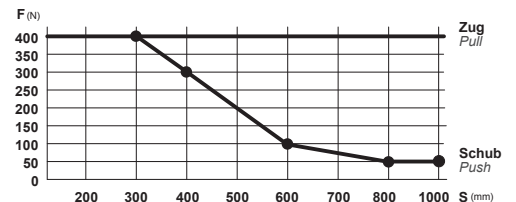

$s > 600$  mm only for pulling application

$F_H$	Pullout force	1.800 N (fastening depended)
-------	---------------	------------------------------

## Chain

Stainless steel, without protruding rivet heads.  
Simple connection to casement brackets.  
Small bending radii allow maximum opening angles of small windows.

## Connecting cable

non-halogen, grey 5 x 0,5 mm<sup>2</sup>, ~ 2 m

$v$	Speed	
-----	-------	--

$s \leq 400$	8,0 mm/s	8,0 mm/s
$s > 400 - 600$	12,0 mm/s	8,0 mm/s
$s > 600$	13,5 mm/s	8,0 mm/s

$s$	Stroke	50 – 1000 mm
-----	--------	--------------

$L$	Length	see order data
-----	--------	----------------

## Feedback contact

limit position „CLOSE“ (max. 24 V, 500 mA)

## Sound pressure level A

$\leq 70$  dB (A)

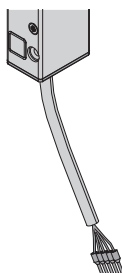
**Option**

AUMÜLLER chain drives have an integrated cable routing with connection sockets on both housing ends. This enables the following options:

- **Wire Click** with various cable lengths  
Part.-No.: 501251 - 3 m cable length / 501252 - 5 m cable length / 501253 - 10 m cable length
- Series connection of several drives into multi drive systems
- Power supply from both sides

**Order Data**

s [mm]	L [mm]	Version	Finish	PU/pcs.	Part.-No.
200	455	KS4 200 S12 24V R	E6/C-0	1	522020
300	551	KS4 300 S12 24V R	E6/C-0	1	522030
400	551	KS4 400 S12 24V R	E6/C-0	1	522040
500	665	KS4 500 S12 24V R	E6/C-0	1	522050
600	665	KS4 600 S12 24V R	E6/C-0	1	522060
800	755	KS4 800 S12 24V R	E6/C-0	1	522080
1000	868	KS4 1000 S12 24V R	E6/C-0	1	522000

**Options**

Special model	PU/pcs.	Part.-No.
<b>Drive housing painted/powder coated in other RAL colours</b>		
<b>Lump sum for coating</b>		<b>516030</b>
Specify at order stage:	1 – 20	<b>516004</b>
	21 – 50	<b>516004</b>
	51 – 100	<b>516004</b>
	from 101	<b>516004</b>
<b>Microprocessor programming S12</b>		
Electronic stroke reduction 24V S12		<b>524190</b>
Programming drives 24V / 230V S12		<b>524180</b>
<b>Optional accessories</b>		
M-COM® Click Configuration module for synchronised multi-drive systems	1	<b>524167</b>
M-COM Configuration module for synchronised multi-drive systems	1	<b>524177</b>

# Data sheet KS4 S12 24V DC L

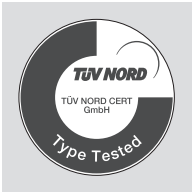

- Application: natural ventilation, RWA, ferralux®-NRWG
- Internal intelligent cut-off switch S12
- Feedback limit position „CLOSE“ (max. 24V, 500 mA)

**Equipment:**

- Additional **AUMÜLLER-Click plug set** for multi-drive operation

**Options:**

- Programmable special functions
- Programmable feedback limit position „OPEN“ (max. 24V, 500 mA)
- M-COM for automatic synchronised run of multi drive systems and automatic sequence control with locking drives (S3 / S12)

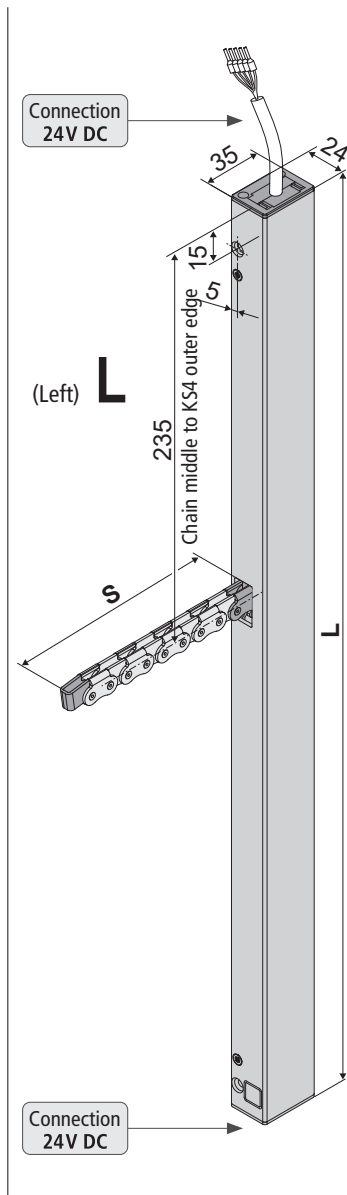

### Technical Data

$U_N$	Rated voltage	24V DC (19 V ... 28 V)
$I_N$	Rated current	0,9 A
$I_A$	Cut-off current	1,2 A
$P_N$	Rated power	22 W
DC	Duty cycle	5 cycles (ED 30 % - ON: 3 min. / OFF: 7 min.)
	Protection rating	IP 32
	Ambient temperature range	-5 °C ... +60 °C
$F_Z$	Pulling force max.	400 N
$F_A$	Pushing force max.	

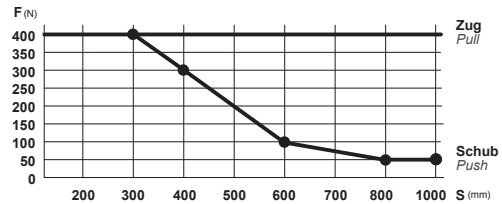

s > 600 mm only for pulling application

$F_H$	Pullout force	1.800 N (fastening depended)
	Chain	Stainless steel, without protruding rivet heads. Simple connection to casement brackets. Small bending radii allow maximum opening angles of small windows.
	Connecting cable	non-halogen, grey 5 x 0,5 mm <sup>2</sup> , ~ 2 m
v	Speed	$s \leq 400$ 8,0 mm/s     8,0 mm/s $s > 400 - 600$ 12,0 mm/s     8,0 mm/s $s > 600$ 13,5 mm/s     8,0 mm/s
s	Stroke	50 – 1000 mm
L	Length	see order data
	Feedback contact	limit position „CLOSE“ (max. 24 V, 500 mA)
	Sound pressure level A	≤ 70 dB (A)

### Option

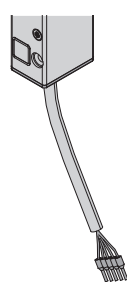

AUMÜLLER chain drives have an integrated cable routing with connection sockets on both housing ends. This enables the following options:

- **Wire Click** with various cabel lengths  
Part.-No.: 501251 - 3 m cable length / 501252 - 5 m cable length / 501253 - 10 m cable length
- Series connection of several drives into multi drive systems
- Power supply from both sides

**Order Data**

s [mm]	L [mm]	Version	Finish	PU/pcs.	Part.-No.
200	455	KS4 200 S12 24V L	E6/C-0	1	520120
300	551	KS4 300 S12 24V L	E6/C-0	1	520130
400	551	KS4 400 S12 24V L	E6/C-0	1	520140
500	665	KS4 500 S12 24V L	E6/C-0	1	520150
600	665	KS4 600 S12 24V L	E6/C-0	1	520160
800	755	KS4 800 S12 24V L	E6/C-0	1	520180
1000	868	KS4 1000 S12 24V L	E6/C-0	1	520100

**Options**

Special model	PU/pcs.	Part.-No.
<b>Drive housing painted/powder coated in other RAL colours</b>		
<b>Lump sum for coating</b>		<b>516030</b>
Specify at order stage:	1 – 20	<b>516004</b>
	21 – 50	<b>516004</b>
	51 – 100	<b>516004</b>
	from 101	<b>516004</b>
<b>Microprocessor programming S12</b>		
Electronic stroke reduction 24V S12		<b>524190</b>
Programming drives 24V / 230V S12		<b>524180</b>
<b>Optional accessories</b>		
M-COM® Click Configuration module for synchronised multi-drive systems	1	<b>524167</b>
M-COM Configuration module for synchronised multi-drive systems	1	<b>524177</b>

**Explanations on the product label**

The product label informs about:

- manufacturer’s address
- article reference number and name
- technical characteristics
- date of manufacturing with firmware version
- certifications
- serial number

**NOTE** Never install and operate damaged products.

In the event of any complaints, please indicate the product serial number (SN) (see product label).

Exemplary representation

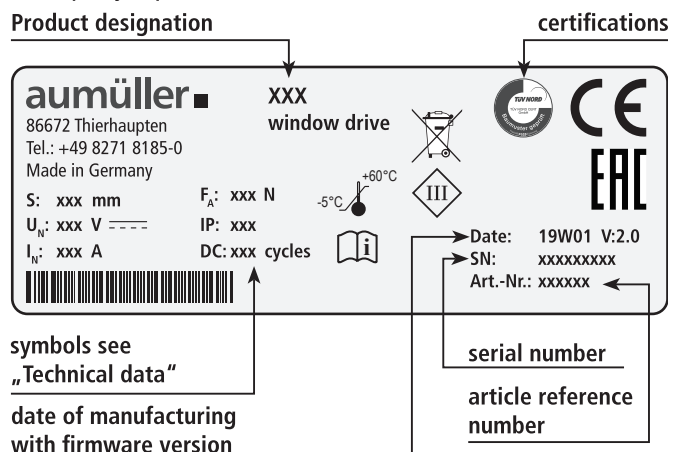

Growing variants and minimum casement dimensions

**HSK** **NSK**

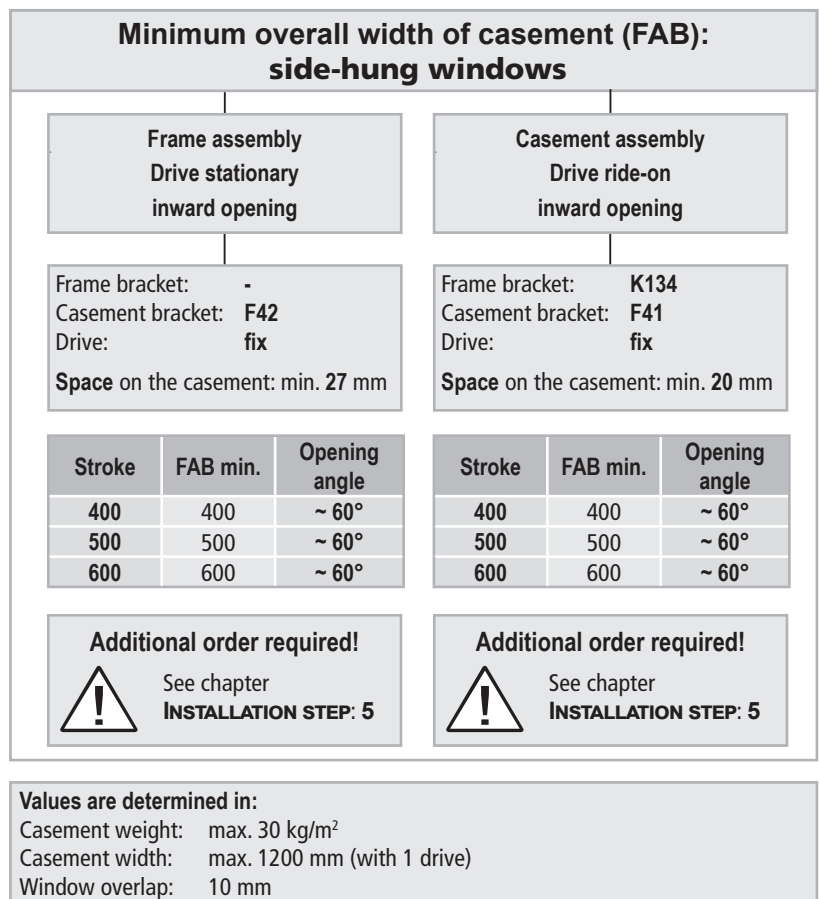
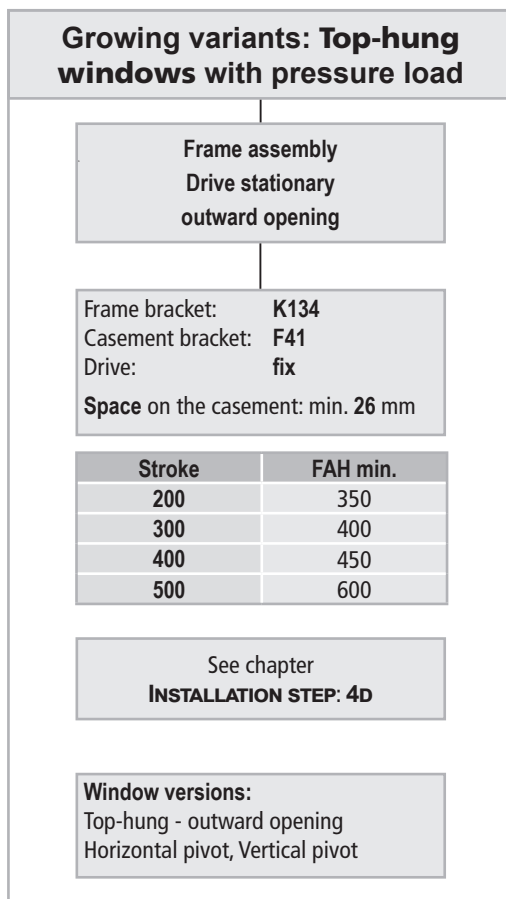
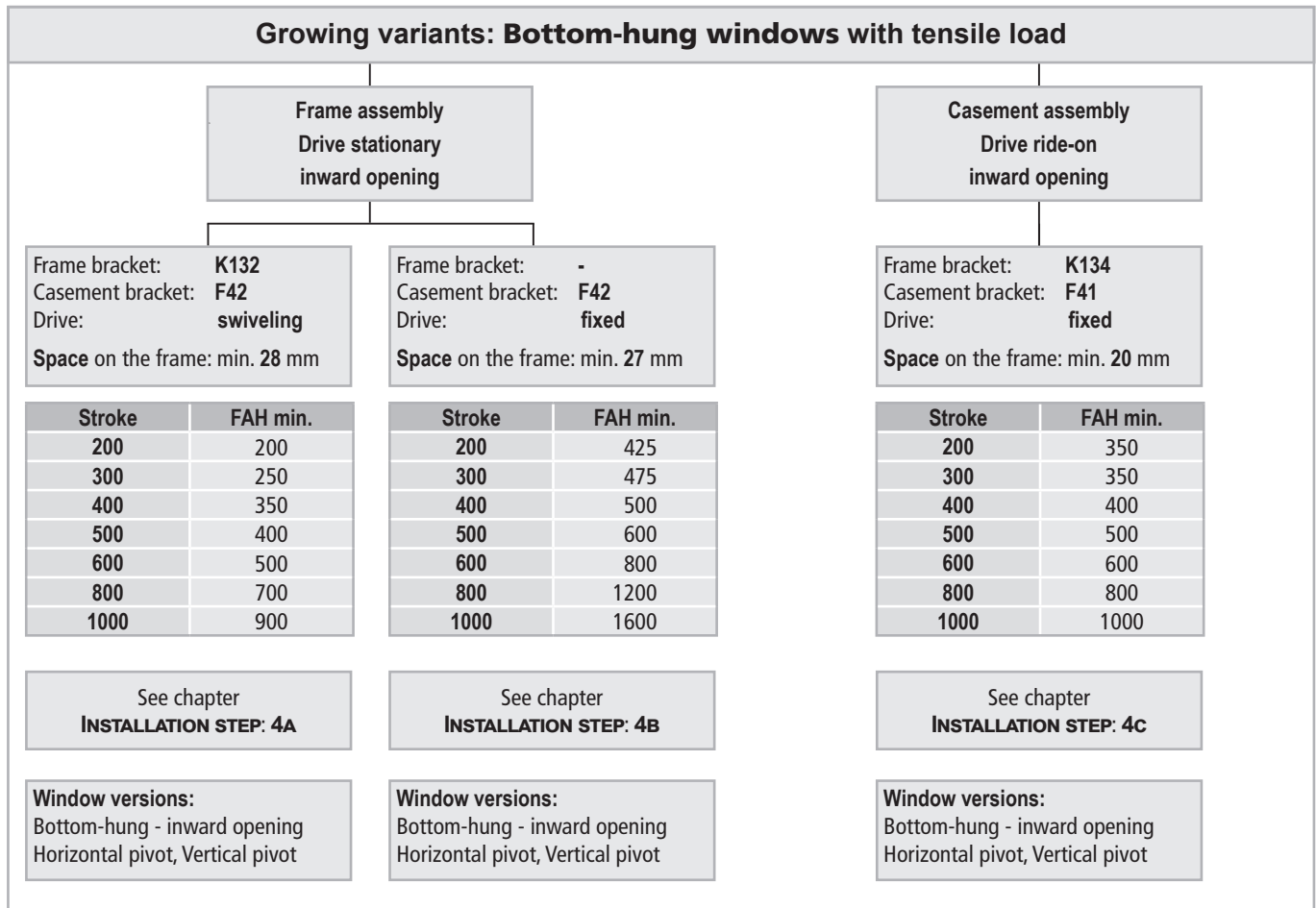

03

## INSTALLATION STEP 1: Inspection before the installation



**WARNING**

Important instructions for a safe installation. Observe all instructions, wrong installation may result in serious injury!

### Storage of drives at the construction site

Protective measures against damages, dust, moisture or contamination shall be taken. Store drives intermediately only in dry and well ventilated rooms.

### Inspection of drives before installation

Check drives and window before installation for good mechanical condition and completeness. The chains / spindles of the drives must be extendable or retractable easily. The casement must run smoothly and the weight must be in balance.

**NOTE**

We recommend the use of our test kit for the inspection of drives with the rated voltage 24V= / 230V~ (see table below). Damaged products may not be operated under any circumstance.

#### Test kit for drives

<b>Order number:</b>	533984
<b>Application:</b>	Test kit to test the running behavior and to support the commissioning of 24 V DC or 230 V AC window drives
<b>Supply voltage:</b>	230V AC
<b>Drive voltage:</b>	24V DC / 230V AC
<b>Drive current:</b>	max. 5 A
<b>Fine fuse:</b>	5.0 A slow-blow
<b>Power Consumption:</b>	1 W / 12 W (Battery level is maintained / charged)
<b>Ambient temperature:</b>	-15 °C ... + 40 °C
<b>Degree of protection:</b>	IP20 / IP65 (case open/closed)
<b>Electrical protection:</b>	Protection class 1, ES1 according to EN IEC 62368-1
<b>Housing:</b>	plastic (PP)
<b>Dimensions (WxHxD):</b>	400 x 300 x 168 mm
<b>Weight:</b>	approx. 5,3 kg
<b>Controls:</b>	3x switches / 2x push buttons
<b>Display:</b>	TFT-Display, farbig
<b>Scope of delivery:</b>	1x test kit / 1x mains plug 4x safety banana plugs 1x operating manual (German, English)



The test procedure of drives may only be performed on a non-slip and secured mat or a test fixture. During the test run the test element must not be interfered with. The test may only be conducted by or under the supervision of expert personnel.

For testing chain drives the chain must be extended and retracted at an angle of approx. 90°. The spindle tubes of spindle drives in round housing tubes must be secured against independent spinning before starting the test to avoid deviations in the integrated position encoder.

### Inspection of the intended use

The planned use of the drive must be checked for compliance with its intended use. If used otherwise the liability and warranty claim expires.

### Predictable misuse

It is imperative that foreseeable misuse of drives is avoided! Here are a few examples:

- do not connect 24 V DC drives to a 230 V AC mains voltage,
- observe synchronous run and sequence control by drives with multiple interconnection (if existing),
- use drives only indoors,
- avoid additional force influences, e.g. transverse forces.

### Testing mechanical requirements

Prior to the start of the installation check whether :

- the support surface and the profile static for the load transmission is sufficient,
- a support construction for the secure fastening of the drives is required,
- cold bridges (thermal separation) are avoidable at action points,
- there is sufficient space for the swivel movement of the drive.

If not, counter measures must be taken!



The support surface of the frame brackets or casement brackets must rest completely on the window or frame profile. There must be no tilting of the fastening elements during extension and retraction of the drives. A safe and solid fastening must be ensured at the window profile.

It is imperative that the sufficiently mechanical stiffness of the fastener type as well as of the swivel range of the drive is observed.



**CAUTION**

If this is not guaranteed another type of fastening or another type of drive must be selected.

## INSTALLATION STEP 2: Installation prerequisite and Installation preparation

The following conditions must be fulfilled for the installation of the drives so they can be properly assembled with other parts and constructed to a complete machine at the window without impairing the safety and health of persons:

1. The design of the drive must fulfill the requirements.
2. The fastening accessories (casement brackets or frame brackets) must fit the window profile; the profile-dependent hole lay-out must be complied with.
3. The space required for the installation of the drive on the frame and casement profile must be sufficient.
4. The window must be in perfect mechanical condition before the installation. It should open and close easily.
5. The fastening material for the installation of the drive must fit the window material (see table).

<b>Wood windows</b>	Wood screws: i.e. DIN 96, DIN 7996, DIN 571  round head with slot, round head with cross, hex head, special type
<b>steel, stainless steel, aluminum windows</b>	Self-tapping screws, thread screws, sheet-metal screws i.e. ISO 4762, ISO 4017, ISO 7049, ISO 7085, DIN 7500  cylinder head with hex socket, internal serration (Torx), Phillips head or external hex head  blind rivet nut
<b>plastic windows</b>	Screws for plastic i.e. DIN 95606, DIN 95607, ISO 7049, ISO 7085, DIN 7500  round head with cross, external hex head, Torx

*Recommendation: if possible, screw through two cavity webs*

### Tools required

- Marker,
- Grains,
- Hammer,
- Screwdriver (slotted-head, cross or Torx) size by site conditions,
- Hexagonal wrench size 3 / 4 / 5 / 6,
- Torque wrench,
- Power drill,
- Threadlock adhesive,
- possibly a tool for blind rivet nuts (size 6).

### Check window data on site

- Measure FAB and FAH.
- Check / calculate weight of casement.  
If unknown, it can be determined approximately with the following formula:

$$G \text{ (Casement weight) [kg]} = \frac{FAB \text{ [m]} \cdot FAH \text{ [m]} \cdot \text{Glass thickness [mm]} \cdot 2,5 \cdot 1,1}{\text{glass-density} \cdot \text{frame share}}$$

- Check / calculate the required drive force and compare with drive data. If unknown, it can be determined approximately with the following formula:

$$F \text{ [N]} = \frac{5,4 \cdot G \text{ [kg]} \cdot s \text{ [m]}}{a \text{ [m]}} \quad \text{Facade}$$

$$F \text{ [N]} = \frac{5,4 \cdot G \text{ [kg]} \cdot FAH \text{ [m]}}{a \text{ [m]}} \quad \text{Roof}$$

- a = Distance of action point to hinges
- F = Drive force
- s = Stroke

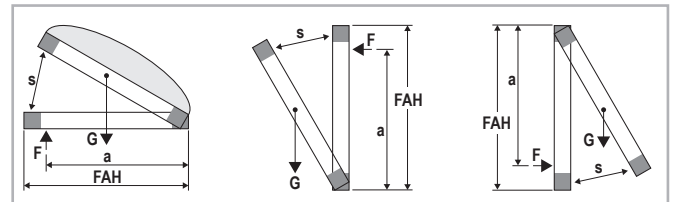

### Scope of delivery:

Prior to assembly, check items quantity in the delivery for completeness.

Accessories for chain drive	
 <b>Information</b>	Assembly and Commissioning Instructions
	<b>Wire Click (1x)</b> je nach Antrieb für 24 V oder 230 V
	<b>AUMÜLLER-Click plug set</b> for multi-drive operation
	Warning sign sticker „Risk of entrapment“ (1x)



**INSTALLATION STEP 3A: Dimensions and hole layouts: casement brackets**

**HSK** **NSK**

Casement bracket F41		Casement bracket F42	
<ol style="list-style-type: none"> <li>1 Casement bracket F41</li> <li>2 1x cylinder head screw M3x20</li> <li>3 1x drilling template</li> </ol>		<ol style="list-style-type: none"> <li>1 Casement bracket F42</li> <li>2 1x baseplate</li> <li>3 1x countersunk screw M4x10</li> <li>4 1x cylinder head screw M3x25</li> <li>5 1x drilling template</li> </ol>	

**INSTALLATION STEP 3A: Dimensions and hole layouts: frame brackets**

**HSK** **NSK**

Frame bracket K132		Frame bracket K134	
<ol style="list-style-type: none"> <li>1 Frame bracket K132</li> <li>2 1x self-tapping screw M5x16</li> </ol>		<ol style="list-style-type: none"> <li>1 Frame bracket K134</li> <li>2 4x self-tapping screws M5x10</li> </ol>	

**INSTALLATION STEP 4A:** Hole layout: frame brackets K132 and casement bracket F42

**HSK** **NSK**

Swiveling drive mounting on the window frame - main closing edge or auxillary closing edge - inward opening windows

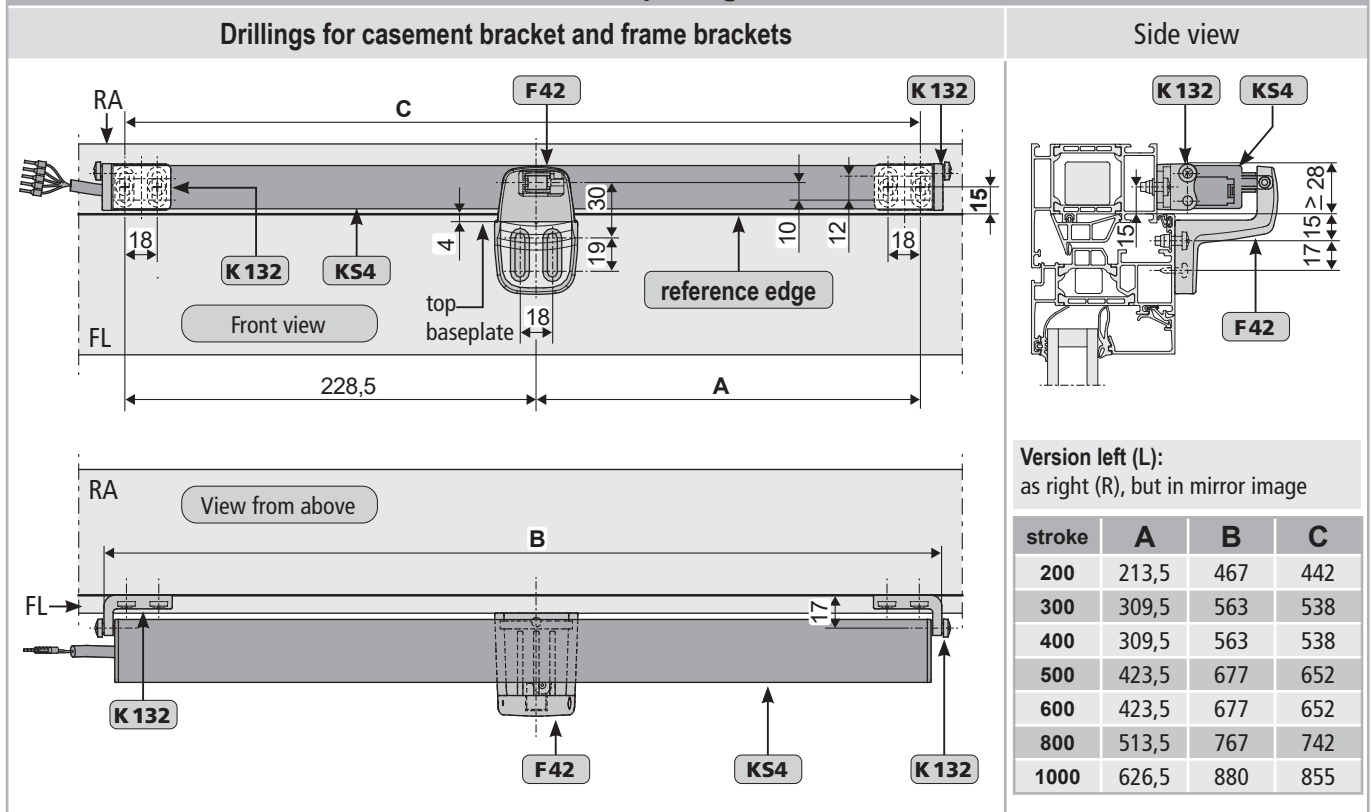

**INSTALLATION STEP 4B:** Hole layout: fixed drive mounting with casement bracket F42

**HSK** **NSK**

Rigid drive mounting directly on the window frame - main closing edge or auxillary closing edge - inward opening windows

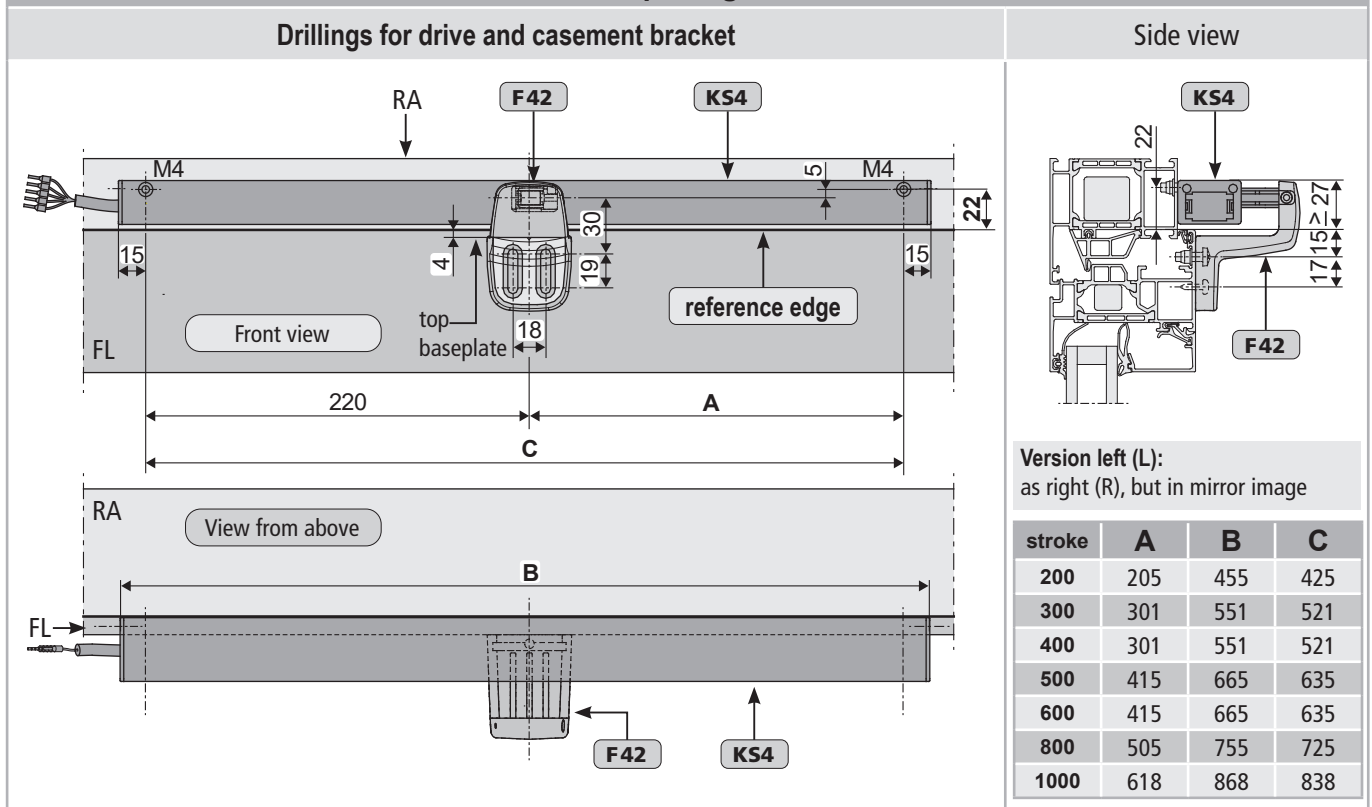

**INSTALLATION STEP 4c:** Hole layout: frame brackets K134 and casement bracket F41

**HSK** **NSK**

Rigid drive mounting on the casement - main closing edge or auxillary closing edge - inward opening windows

**Drillings for casement bracket and frame brackets**

**Side view**

**Version left (L):**  
as right (R), but in mirror image

stroke	A	B	C
200	220,5	472	456,5
300	316,5	568	552,5
400	316,5	568	552,5
500	430,5	682	666,5
600	430,5	682	666,5
800	520,5	772	756,5
1000	633,5	885	869,5

**INSTALLATION STEP 4D:** Hole layout: frame brackets K134 and casement bracket F41

**HSK**

Rigid drive mounting on the window frame - main closing edge - outward opening windows

**Drillings for casement bracket and frame brackets**

**Side view**

**Version left (L):**  
as right (R), but in mirror image

stroke	A	B	C
200	220,5	472	456,5
300	316,5	568	552,5
400	316,5	568	552,5
500	430,5	682	666,5
600	430,5	682	666,5
800	520,5	772	756,5
1000	633,5	885	869,5

**INSTALLATION STEP 5: Additional order for drive chain with „chain stretched on one side“ on side-hung windows** **NSK**

**Additional order**

<p style="text-align: center;"><b>Right: Version 2</b> for windows DIN left</p> <p><b>Part. No. 521524</b> Chain stretched on one side</p> <p style="text-align: center;"><b>KS4 R</b></p> <p style="text-align: center;"><b>R</b> (Right drive)</p>	<p style="text-align: center;"><b>Left: Version 1</b> for windows DIN right</p> <p><b>Part. No. 521526</b> Chain stretched on one side</p> <p style="text-align: center;"><b>KS4 L</b></p> <p style="text-align: center;"><b>L</b> (Left drive)</p>
--	---

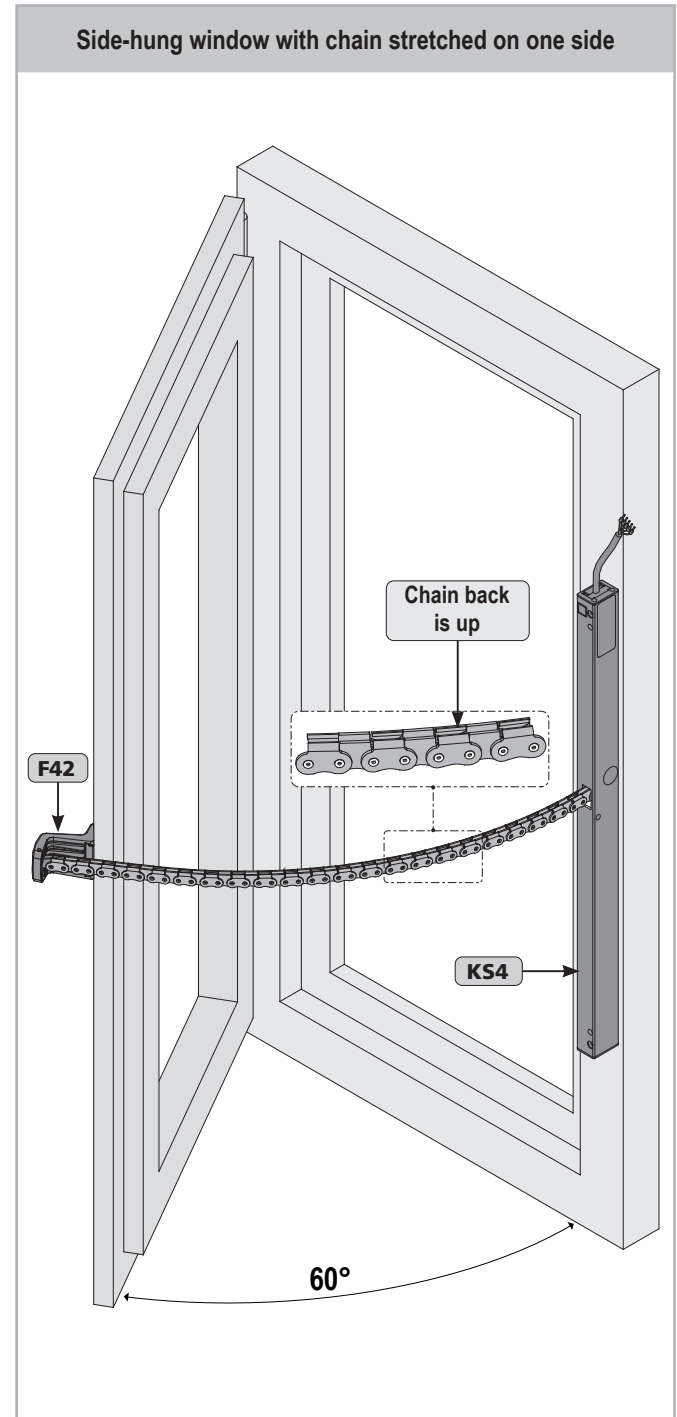
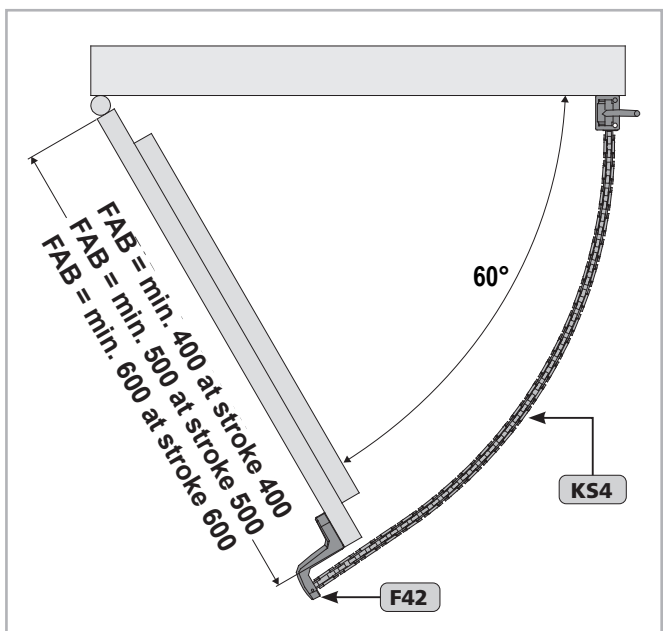

- When installing FAB < 400 mm with an opening angle between 60° and 90° it is essential to also observe the information in the installation instruction "KS4 400 S12 24V with side bend for side-hung windows - surface mounting" (9000022080).**
- When installing FAB > 600 mm with an opening angle approx. 70° it is essential to also observe the information in the installation instruction "Drehvolution - KS4" (9000022040).**
- See our homepage: [www.aumueller-gmbh.de](http://www.aumueller-gmbh.de)

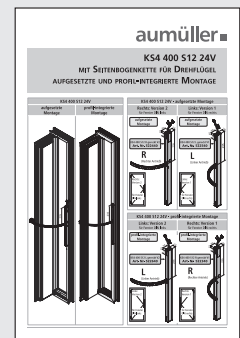
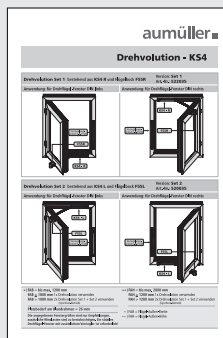

**INSTALLATION STEP 6A:** Hole layout: casement bracket F42  
(Drive at side / Tandem)



Rigid drive mounting directly on the window frame - auxiliary closing edge - inward opening

Tandem application / Combination right / left

stroke	A	B	C	X	Max. opening
200	205	455	425	≥ 450	45°
300	301	551	521	≥ 650	50°
400	301	551	521	≥ 650	60°
500	415	665	635	≥ 850	60°
600	415	665	635	≥ 850	60°
800	505	755	725	≥ 1050	60°
1000	618	868	838	≥ 1250	60°

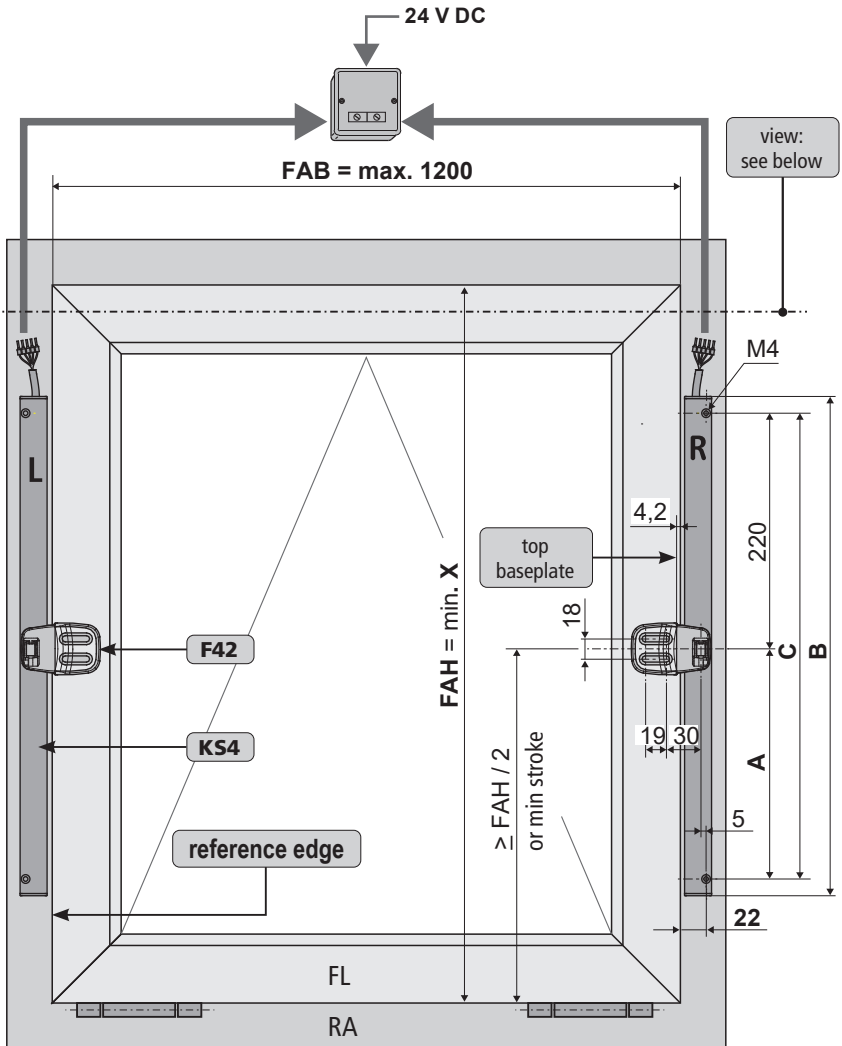

- only for bottom-hung casements - inward opening windows
- respect max. pulling forces of drives.
- cable exit (power supply) on top.

From FAB > 1200 mm is a locking drive required!

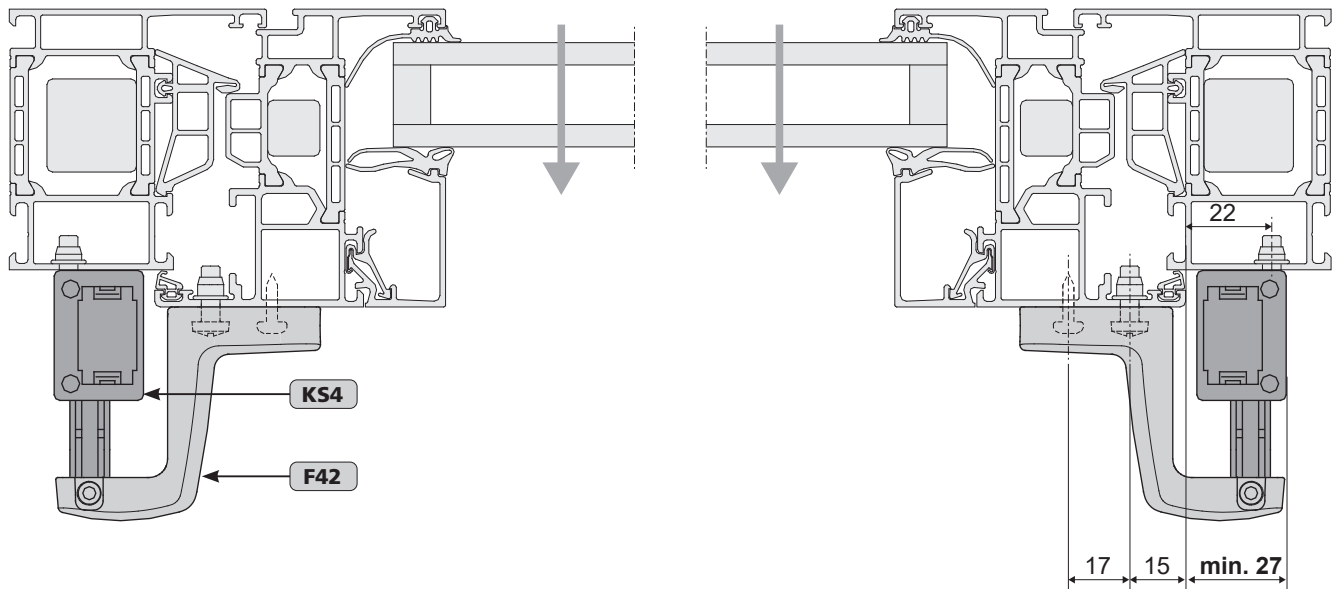

**INSTALLATION STEP 6B:** Hole layout: frame brackets K134 + casement bracket F41 (Drive at side / Tandem)

Swiveling drive mounting on the window frame - auxillary closing edge - inward opening

Tandem application / Combination right / left

**Overview table for 60° opening angle**

stroke	A	B	C	D	X
200	220,5	472	211,5	438,5	≥ 450
300	316,5	568	307,5	534,5	≥ 650
400	316,5	568	307,5	534,5	≥ 650
500	430,5	682	421,5	648,5	≥ 850
600	430,5	682	421,5	648,5	≥ 850
800	520,5	772	511,5	738,5	≥ 1050
1000	633,5	885	624,5	851,5	≥ 1250

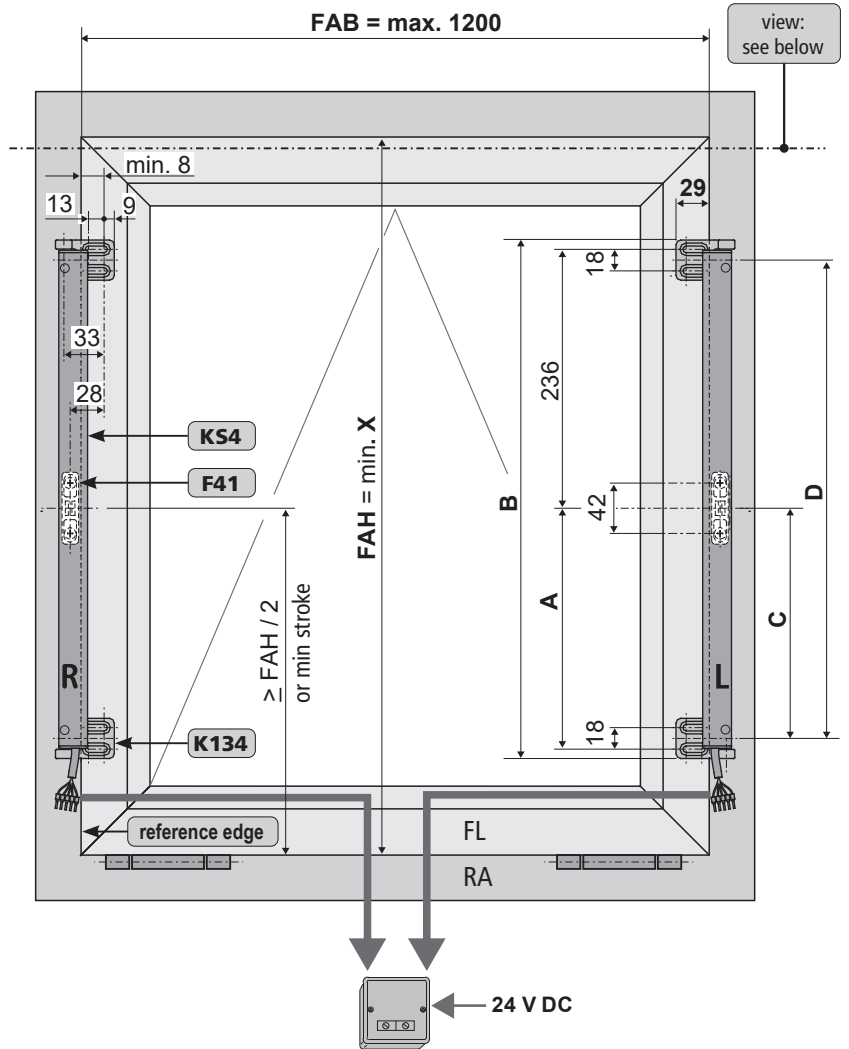

- only for bottom-hung casements - inward opening windows
- respect max. pulling forces of drives.
- cable exit (power supply) on top.

From FAB > 1200 mm is a locking drive required!

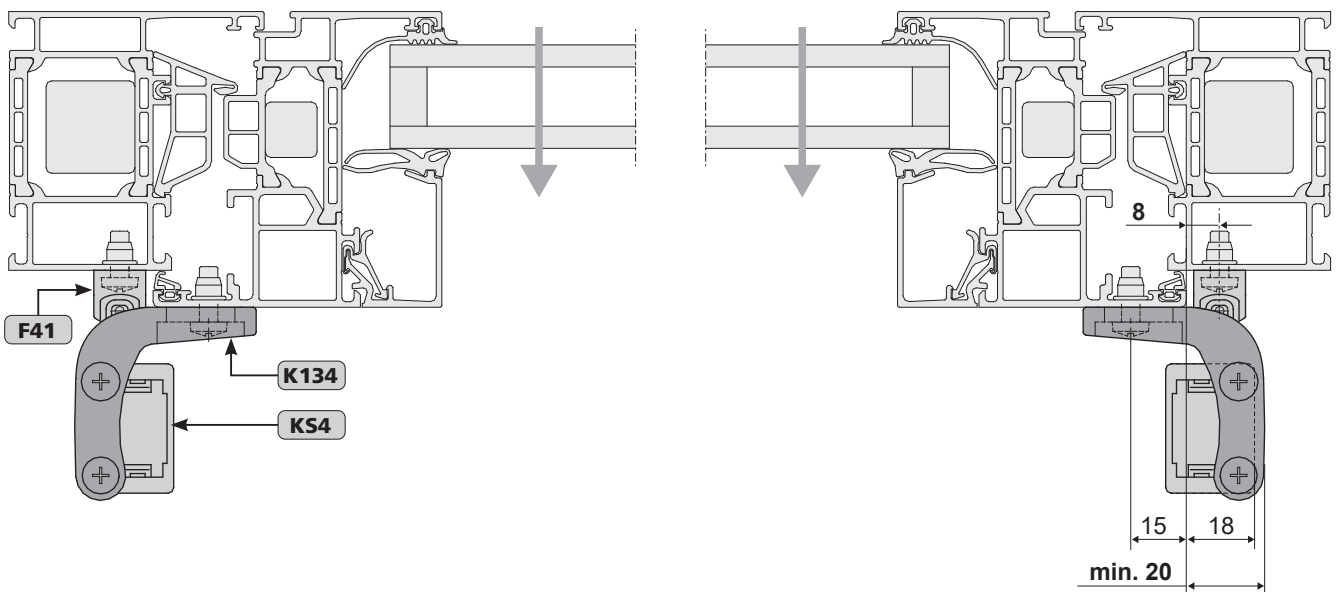

### INSTALLATION STEP 7: Drill holes according to mounting variants

**HSK** **NSK**

- Determine fastenings.
- Produce drill holes with appropriate cross-section. For the mounting dimensions please refer to the above-mentioned hole layout drawings (see chapter „INSTALLATION STEPE 3 + 4“ or project-specific documents and drawings).

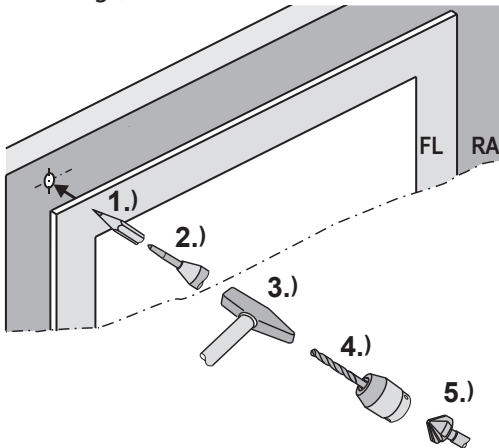

Do not drill into the drive. Chips can accumulate in the drive!



Carefully clear away drilling swarfs to prevent seals from being damaged. Avoid surface scratches, for example by using masking tape.

- Secure fasteners against loosening; e.g. by applying removable thread-locking compound such as "Loctite".

#### Alternative: Drilling template

Boreholes can be made using a drilling template. The bore-hole intervals are shown and dimensioned on the template.

- The intervals must coincide with the window profile.
- Remove the protective film from the drilling template.
- Stick drilling template on the window profile.



Smooth and taut pull drilling template when sticking.

Drilling template	
for frame bracket K134 and casement bracket F41	for frame bracket K132 and casement bracket F42
K 134 und F41	K 132 und F42

### INSTALLATION STEP 8A: Swiveling drive mounting on the window frame

- main closing edge or auxillary closing edge  
- inward opening windows

**HSK**  
**NSK**

- Fasten frame bracket **K132** ❶ with screws (M5).



Make sure they are parallel to casement edge.

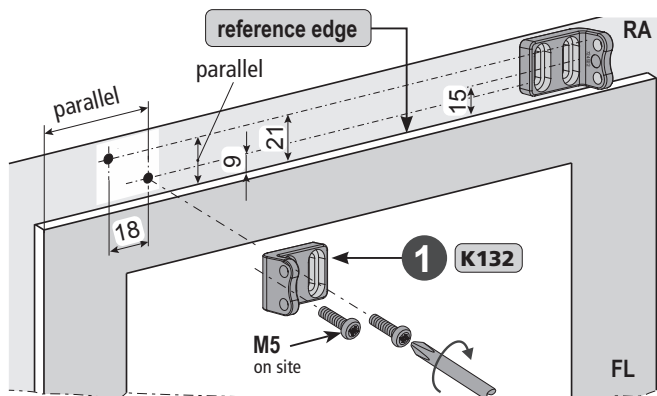

**NOTE**

If required, use washers corresponding to the used screws.

	<b>❶</b> Frame bracket K132 <b>❷</b> 1x self-tapping screw M5x16
max. 4 Nm	

	<b>❸</b> Casement bracket F42 <b>❹</b> 1x baseplate <b>❺</b> 1x screw M4x10 <b>❻</b> 1x screw M3x25
--	--



**HSK** **NSK**

- Attach drive to the frame brackets **K132** ①.
- Secure the drive with screws ②.



Drive should freely swivel - between frame brackets **K132** ①.

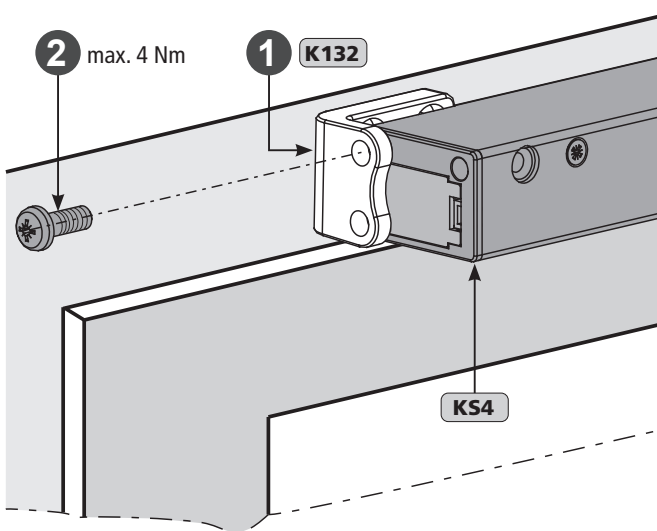

- Screw the baseplate ④ from casement bracket **F42** ③ onto casement (**M5**). If necessary, use washers.

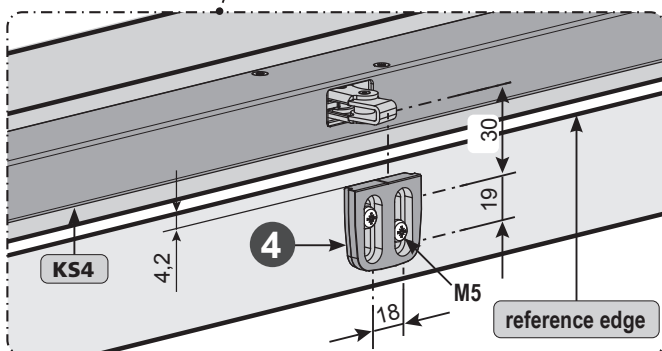
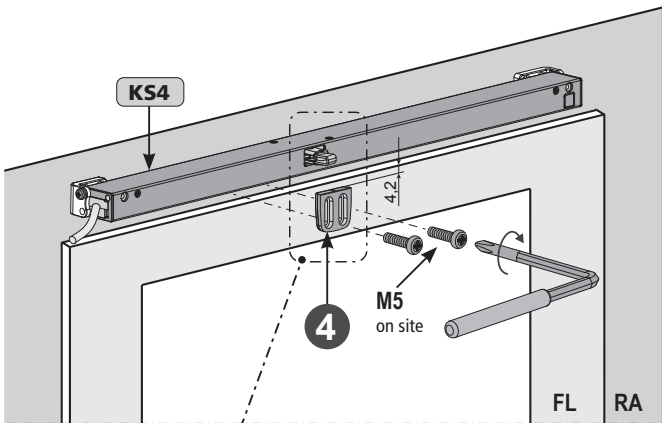

- Slide casement bracket **F42** ③ on the baseplate ④ and secure with screw ⑤.

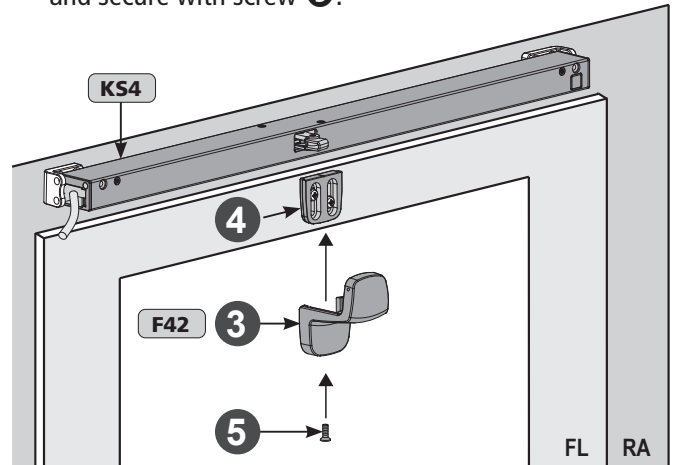

- Connect control voltage (e.g. using a tester) and move out the chain approx. 100 mm.

**NOTE** For multi-drive operation actuate all drives together.

- Secure chain in the casement bracket **F42** ③ with screw ⑥.

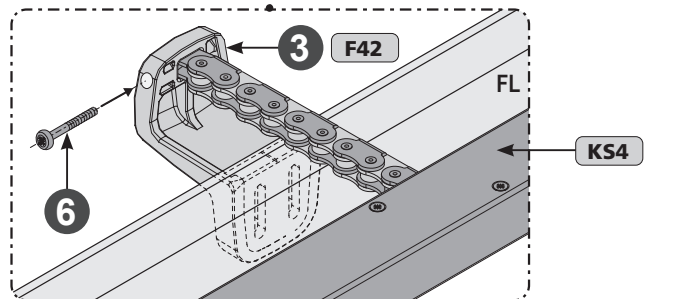
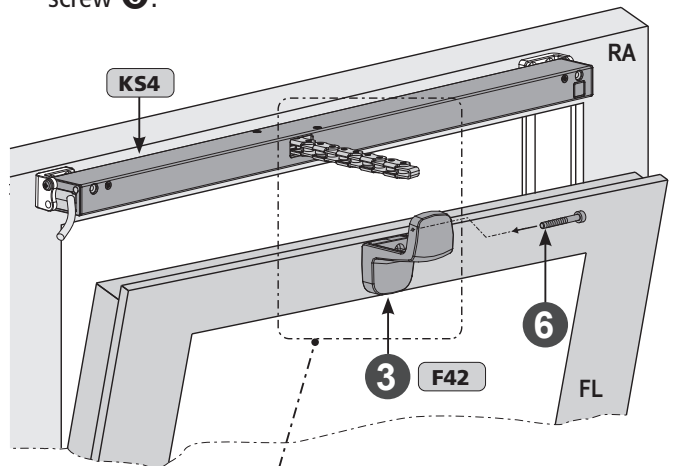

Note cable routing! (see chapter „Cable routing“)  
 Note soft run mode! (see chapter „Soft run mode“)  
 Check swiveling area! (see chapter „Safety check and Performing Test Run“).



**INSTALLATION STEP 8B:** Rigid drive mounting directly on the window frame  
 - main closing edge or auxillary closing edge  
 - inward opening windows

**HSK** **NSK**

■ Screw the drive onto window frame (M4).



Make sure they are parallel to casement edge. The drive body must lie completely flush on the window frame surface.

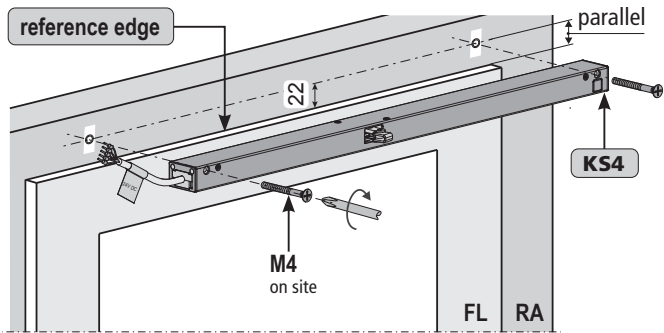

	<b>1</b> Casement bracket F42
	<b>2</b> 1x baseplate
	<b>3</b> 1x countersunk screw M4x10
	<b>4</b> 1x screw M3x25

■ Screw the baseplate 2 from casement bracket F42 1 onto casement (M5). If necessary, use washers.

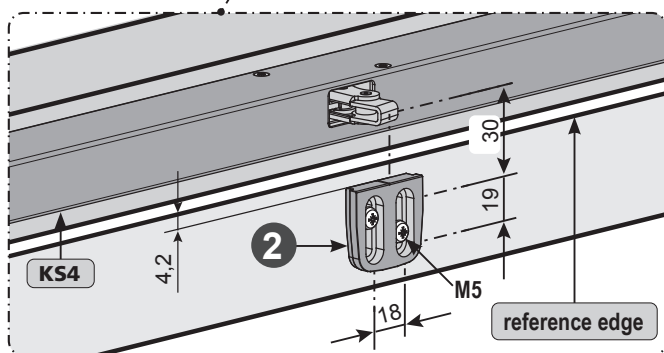
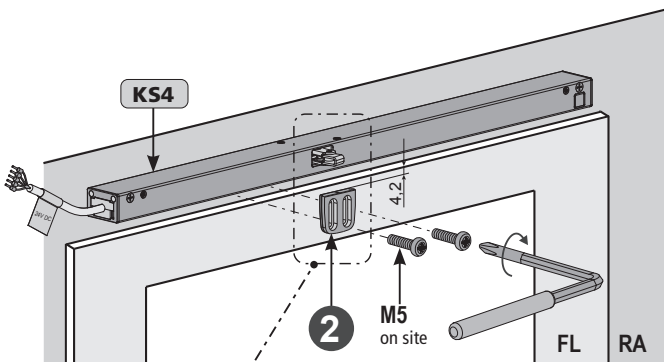

■ Slide casement bracket F42 1 on the baseplate 2 and secure with screw 3.

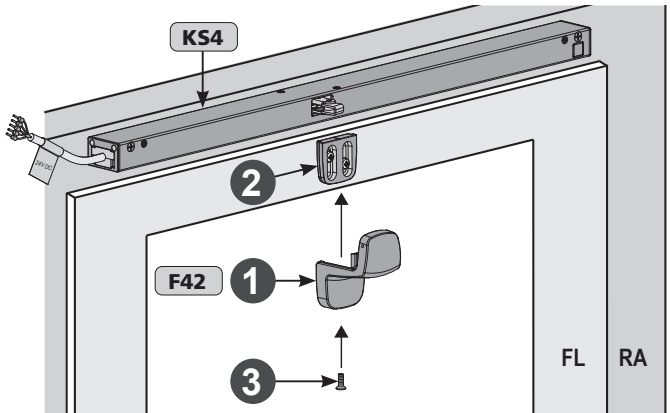

■ Connect control voltage (e.g. using a tester) and move out the chain approx. 100 mm.

**NOTE**

For multi-drive operation actuate all drives together.

■ Secure chain in the casement bracket F42 1 with screw 4.

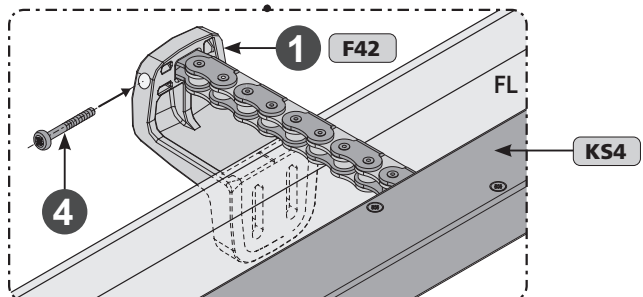
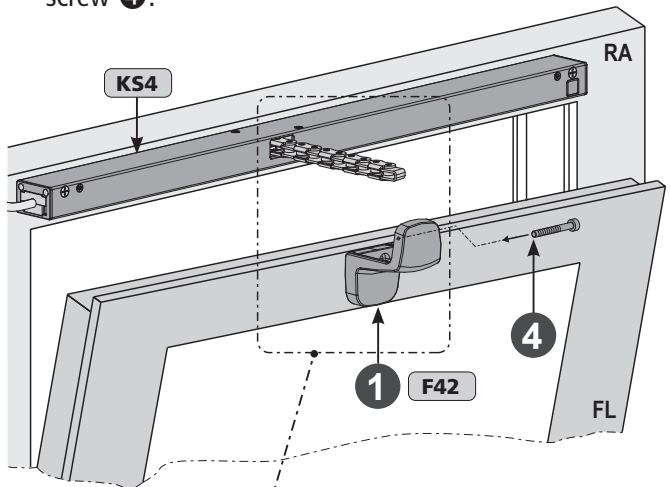

Note cable routing!  
(see chapter „Cable routing“)

Note soft run mode!  
(see chapter „Soft run mode“)

Check swiveling area! (see chapter „Safety check and Performing Test Run“).



# INSTALLATION STEP 8c: Rigid drive mounting on the casement

- main closing edge or auxillary closing edge  
- inward opening windows

**HSK** **NSK**

- Fit casement bracket F41 1 with screws (M5).



Make sure it is parallel to casement edge. „Casement bracket“ center and „chain output“ must be in line.

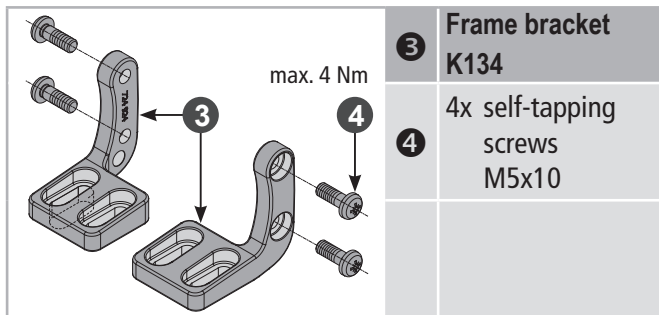
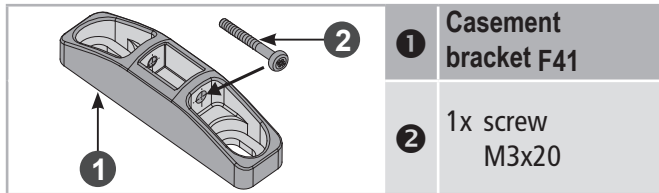
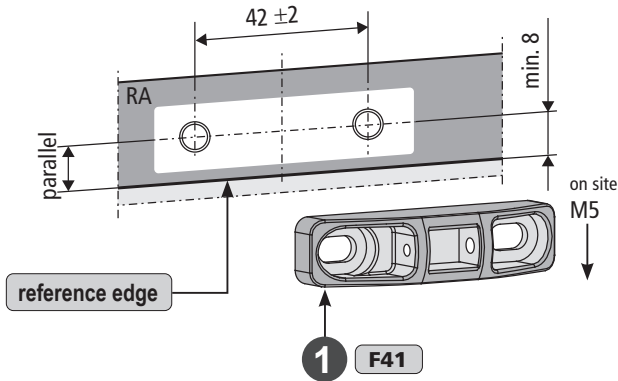

- Frame brackets K134 3 anscrewed (M5).



Make sure they are parallel to casement edge.

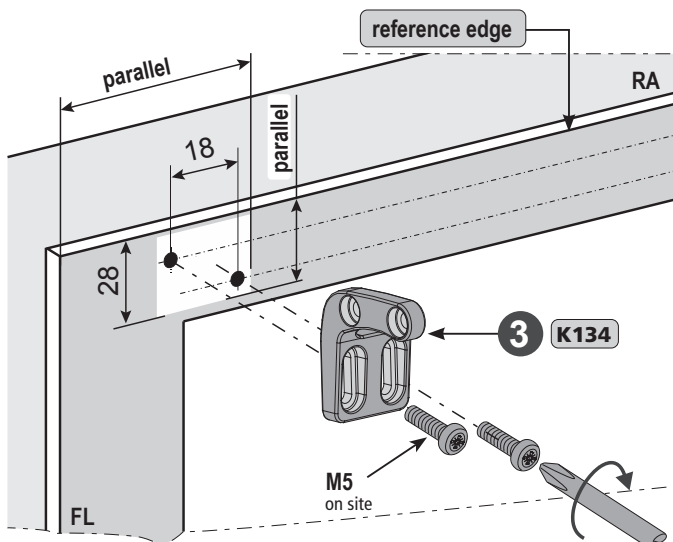

**NOTE**

If required, use washers corresponding to the used screws.

- Attach drive to the frame brackets K134 3.
- Secure the drive with screws 4.

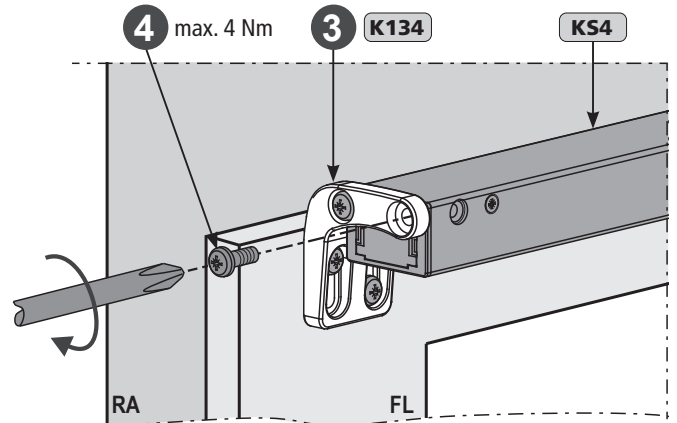

- Connect control voltage (e.g. using a tester) and move out the chain approx. 100 mm.

**NOTE**

For multi-drive operation actuate all drives together.

- Secure chain in the casement bracket F41 1 with screw 2.

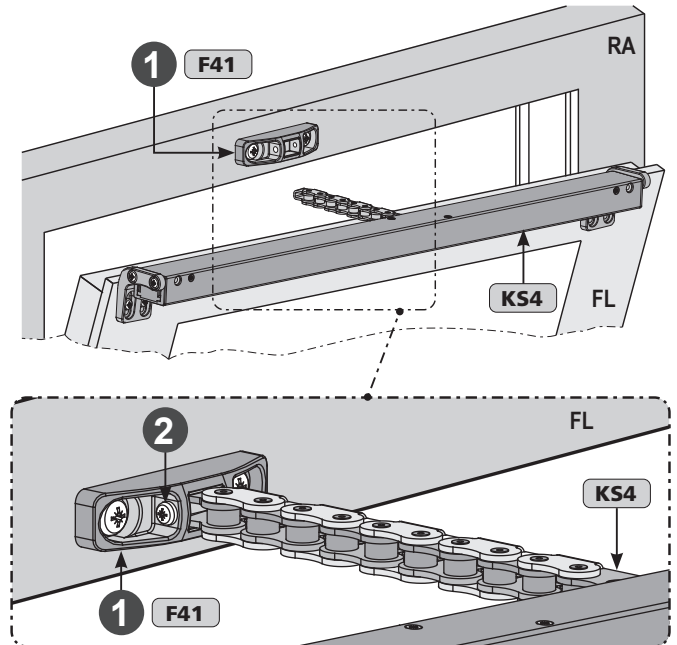

Note cable routing! (see chapter „Cable routing“)

Note soft run mode! (see chapter „Soft run mode“)

Check swiveling area! (see chapter „Safety check and Performing Test Run“).

# INSTALLATION STEP 8D: Rigid drive mounting on the window frame

- main closing edge  
- outward opening windows

HSK

Fit casement bracket **F41** ① with screws (M5).



Make sure it is parallel to casement edge.  
„Casement bracket“ center and „chain output“ must be in line.

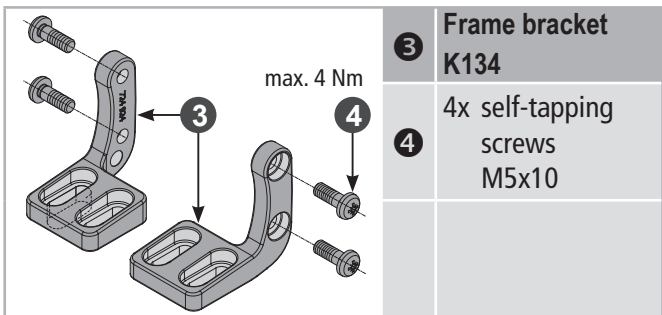
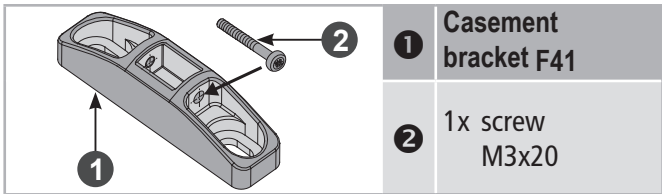
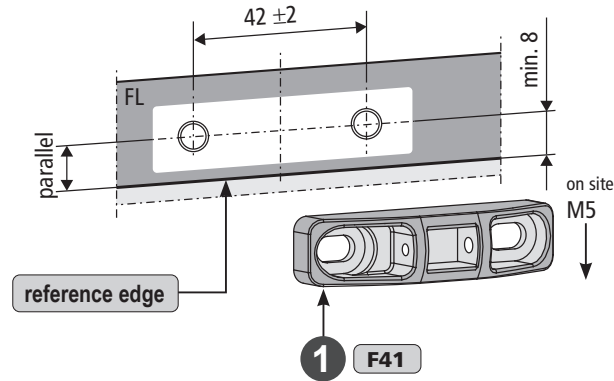

Fasten frame bracket **K134** ③ with screws (M5).



Make sure they are parallel to casement edge.

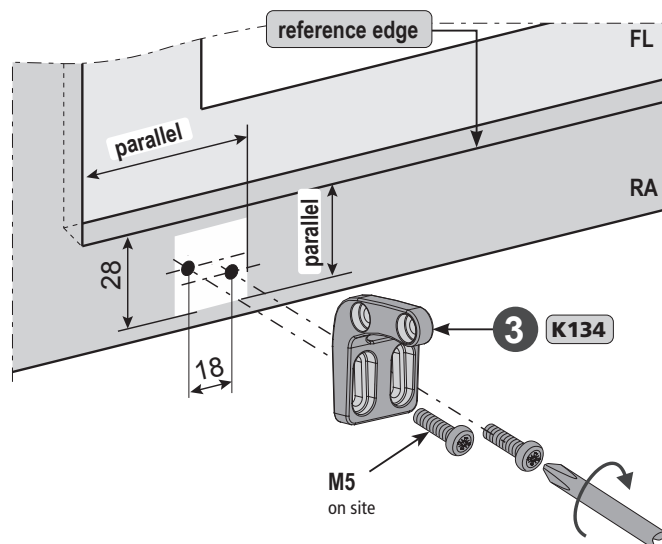

NOTE

If required, use washers corresponding to the used screws.

- Attach drive to the frame brackets **K134** ③.
- Secure the drive with screws ④.

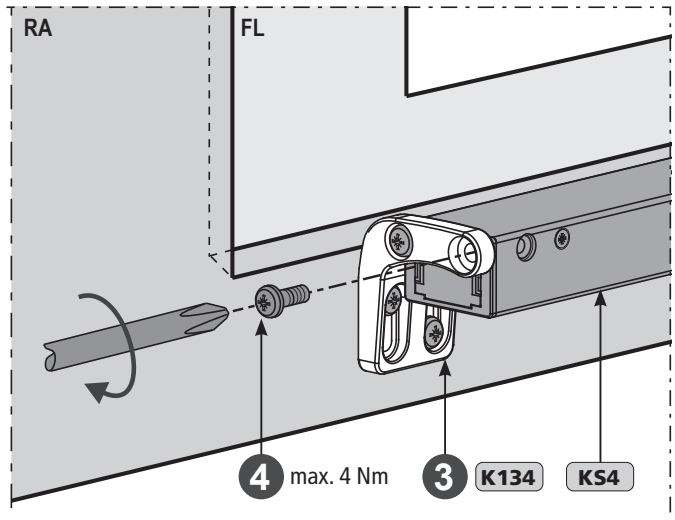

- Connect control voltage (e.g. using a tester) and move out the chain approx. 100 mm.

NOTE

For multi-drive operation actuate all drives together.

- Secure chain in the casement bracket **F41** ① with screw ②.

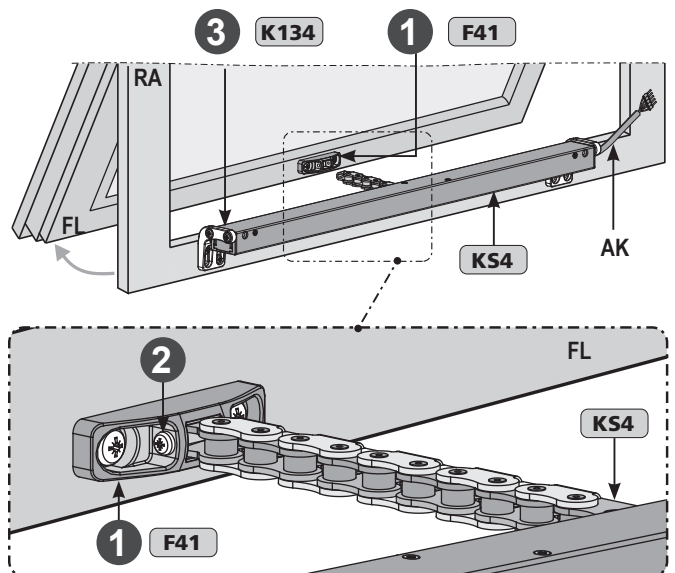

Note cable routing!  
(see chapter „Cable routing“)

Note soft run mode!  
(see chapter „Soft run mode“)

Check swiveling area! (see chapter „Safety check and Performing Test Run“).



## INSTALLATION STEP 9: Cable routing - on the casement or frame

**HSK** **NSK**

### Cable routing on or in the casement

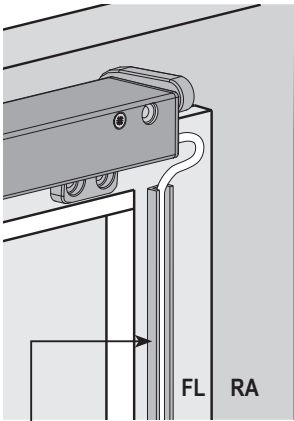
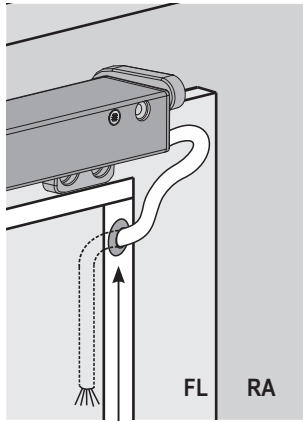
Cable on casement	Cable in glazing bead
 <p>Cable duct glued on (in addition secured with countersunk screws against breaking away).</p>	 <p>Drill hole in glazing bead (cable bushing protects against damage to cable).</p>
<p><b>Connection cable routing on the casement:</b></p> <ul style="list-style-type: none"> <li>Cable must be protected against damage (shearing-off, kinking, splitting), i.e. by using bushings.</li> </ul>	

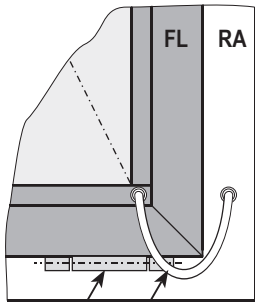
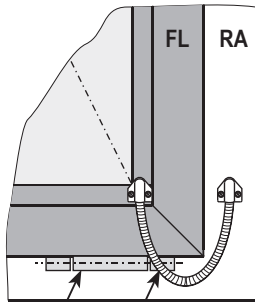

Upon removal of the glazing bead is the danger that the glass may fall.

Cable crossover <u>without</u> protective cable hose	Cable crossover <u>with</u> protective cable hose
 <p>BD AK</p>	 <p>BD protective cable hose</p>
<p><b>Connection cable routing on the hinge side:</b></p> <ul style="list-style-type: none"> <li>Make sure that during opening or closing procedure the cable will not be damaged by shearing-off, kinking, crushing.</li> <li>Protect cable feedthrough in profile e.g. by using cable bushings, cable transitions.</li> </ul>	

### Cable routing on the frame

- Route cable on the frame or mullion/transom. Cable must be protected against damage (shearing-off, kinking, splitting).

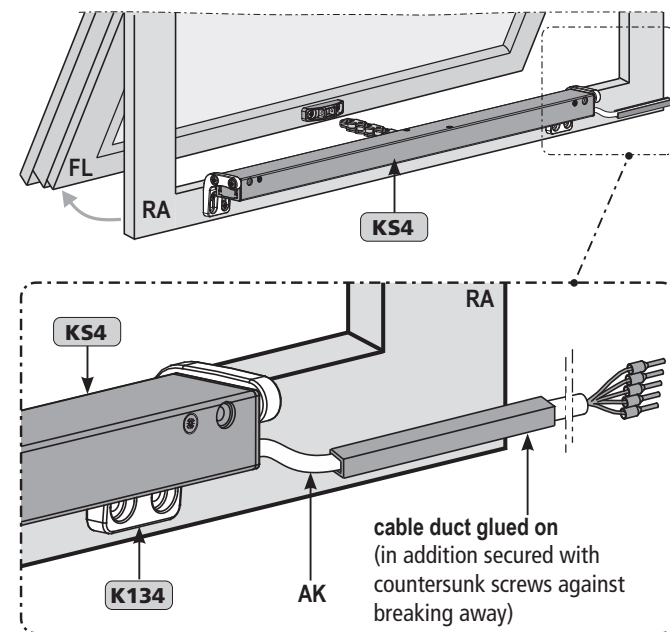

## INSTALLATION STEP 10: Electric connection



Make sure when establishing the connection that there is no voltage at the terminals!  
Unused wires must be safely insulated!

The running direction of the drive may be changed by interchanging (polarity reversal) the wires „BN – (brown)“ - „BU – (blue)“.

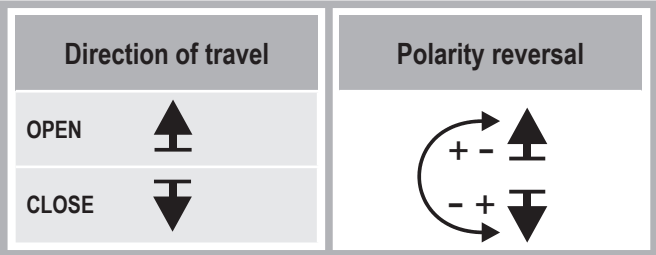

### Connection assignment

BN	+	-
BU	-	+

WH is used for communication (in systems with synchronized multi-drive operation)

Standard **CLOSE** / Optional **OPEN**:  
contact max. 24 V, 500 mA (SELV) (min. 10mA)

### Wire colour coding

Wire colour coding	DIN IEC 757
black	BK
white	WH
brown	BN
blue	BU
green / yellow	GN / YE
green	GN
violet	VT
grey	GY

### Multi-drive operation with master and slave

**WH connection.**  
Drives do not work, if not connected.

master      slave

AK      AK

WH

BN +      BU -

24 V DC control from control unit

junction box site-supplied

The programming of the drives in multi-drive occurs at factory or on site with UniPC

WH is used for communication, with synchronized multi-drive operation.

Optional: 1 to 4 drives and max. 2 locking drives are possible.

### Multi-drive operation with M-COM

**WH connection.**  
Drives do not work, if not connected.

drive 1      drive 2

AK      AK

WH

BN +      BU -

M-COM

24 V DC control from control unit

junction box site-supplied

WH is used for communication, with synchronized multi-drive operation.

Optional: 1 to 4 drives and max. 2 locking drives are possible.



# Electric connection configured with M-COM

## Multi-drive operation with M-COM and locking drive - series connection

AUMÜLLER chain drives have an integrated cable routing with connection sockets on both housing ends. This enables the connect multiple drives.

Individual configuration

Remove the filler plug and AUMÜLLER Click plug set install.

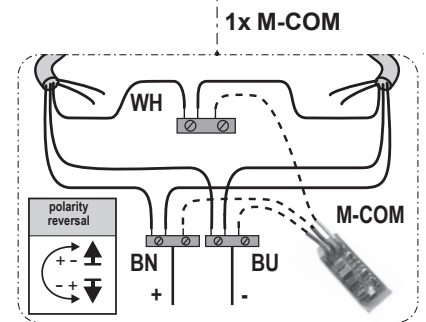
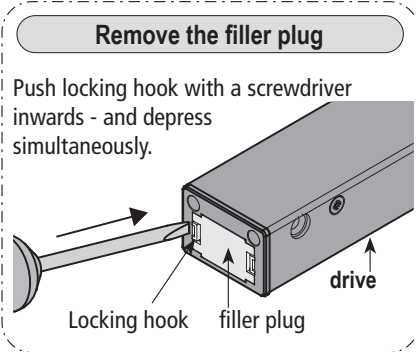
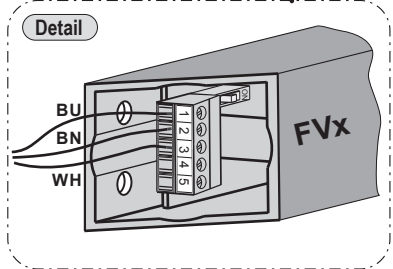
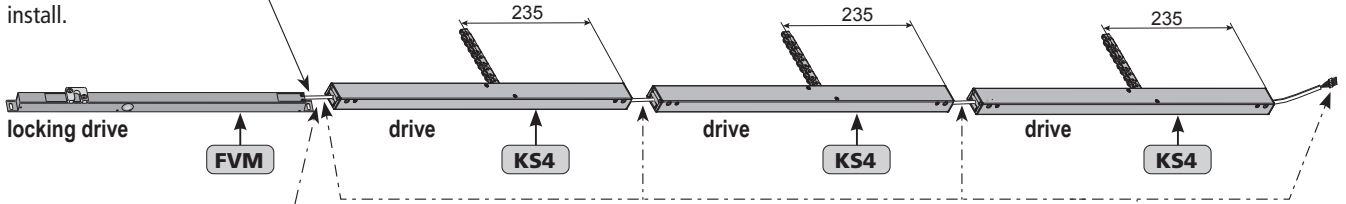

A maximum of **three individual drives** and **one locking drive** in series connection possible. Configuration is done by M-COM.

BN	=	brown
BU	=	blue
WH	=	white

## Multi-drive operation with M-COM and locking drive - star wiring

Options:  
Programmable special functions and sequence control with locking drive. In multi-drive systems can be used, up to **four individual drives** and **two locking drives**. Configuration is done by M-COM.

Individual configuration

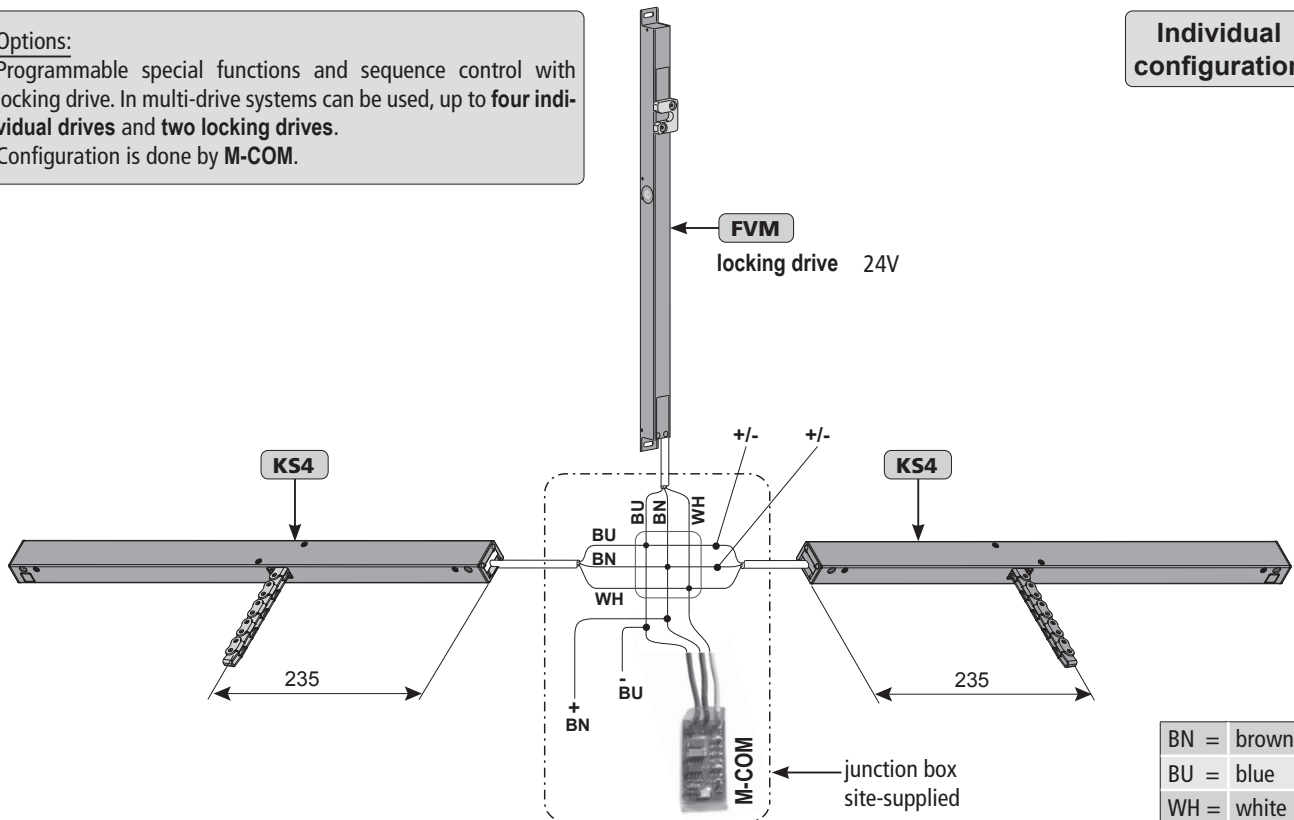

BN	=	brown
BU	=	blue
WH	=	white



## INSTALLATION STEP 11: Supply lines of Control Unit to the Drives

Observe current regulations and guidelines regarding the "Fire behavior of building materials-circuit integrity maintenance of electric cable systems" (E30, E60, E90) and the prescribed constructional regulations!

**RECOMMENDATION**

For safety reasons a cable of the next higher wire cross section should be selected.

**Formula to calculate**

the required wire cross-section of a supply line

**24V**

$$A \text{ mm}^2 = \frac{I_{A \text{ (total)}} * L_m \text{ (length supply line)} * 2}{2,0V_{\text{ (voltage drop)}} * 56 \text{ m} / (\Omega * \text{mm}^2)}$$

**Calculation example**

Available data:

- cut-off current per drive (i. e. 2 x 4.0A) from data sheet
- length to be bridged from the last window to the control unit (i. e. 10 meters)

$$A = \frac{(2 * 4,0A) * 10m * 2}{2,0V * 56m / (\Omega * \text{mm}^2)}$$

A = 1,42mm<sup>2</sup> -> 1,5mm<sup>2</sup> chosen

## Laying and connecting the drive cable

- Avoid extreme temperature differences in the installation area (danger of condensation).
- Set clamping point close to window and ensure accessibility.
- Ensure expansion possibilities of the drive and the drive cable.
- Consider the cable length and the cross sections of the drives supply lines.

## INSTALLATION STEP 12: Soft run mode

### Soft run setting for drives with S12

The drive has an electronic position detection. Just before the CLOSED position the chain retracts with reduced speed in the soft run mode, to protect the window and the drive.

- In soft run mode the zero-point - and thus the CLOSE-position of the window - is recognized.
- The drives with **S12** must turn off in the soft run range (about 40 mm in front of the CLOSE-position).
- In closing direction in case of overload outside the 40 mm soft run range, the chain moves out by approximately 10 mm.

## INSTALLATION STEP 13: Safety check and Test run

Check the mounted system for its safety; perform test run and commissioning.

### Safety test:

- Connect operating voltage.
- Check fastening (frame brackets, casement brackets) for firm fit or tightening.

### Test run:

- Visual inspection of casement movements.
- Stop immediately by malfunction!
- Pay attention to collision with facade construction and correct installation, if required.

### Risk evaluation:

Before operating a power-operated window to which window drives were mounted, which were sold by the manufacturer as incomplete machines according to installation declaration, the possible risk to ahazard of persons must be determined, evaluated and minimized by taking appropriate technical measures in accordance with the Machinery Directive. Separate documents for performing a risk assessment can be downloaded from the homepage of

**Firm AUMÜLLER AUMATIC GmbH**  
([www.aumueller-gmbh.de](http://www.aumueller-gmbh.de)).

## Operation of the power-operated window

When operating the power-operated window safety instructions must be observed, specifically those pertaining to commissioning, operation and maintenance.

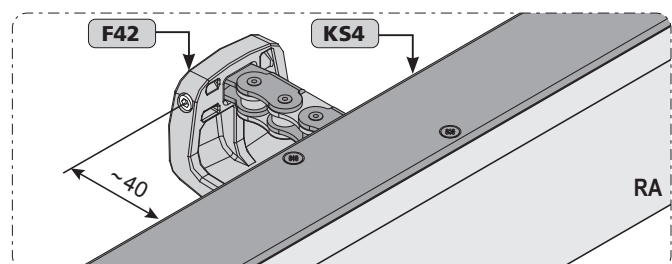
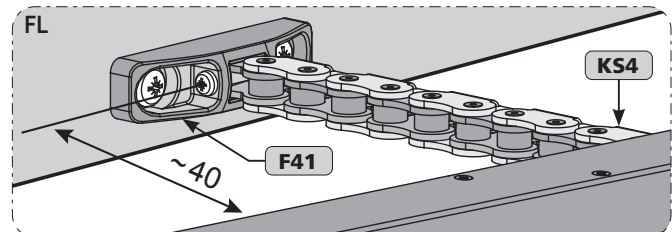

## Wire Click - site-supplied customised construction

The **Wire Click** enabling the use of site-supplied cable. It simplifies assembly and the electrical connection of the drives.

- Loosen the screws ② and remove the housing cover ①.

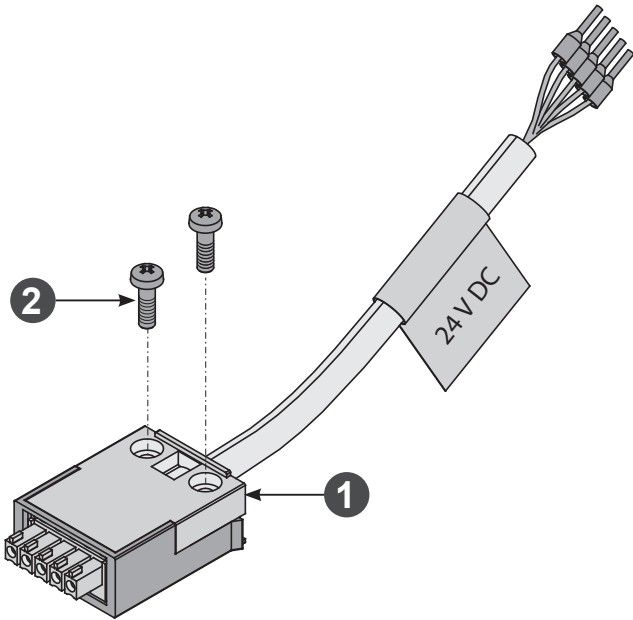

**NOTE**

Locking hooks - at the housing cover ① - prevent withdrawal of the plug under tensile load.

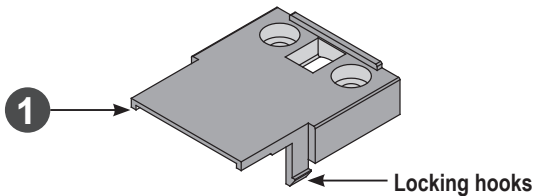

- On the underside of the plug housing ③ are two openings for releasing the locking hooks. Push locking hook with a screwdriver inwards - and depress simultaneously.

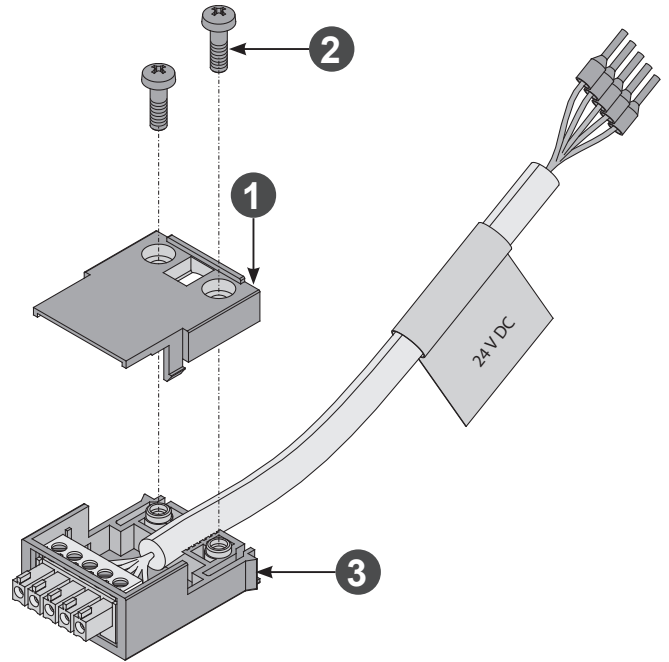
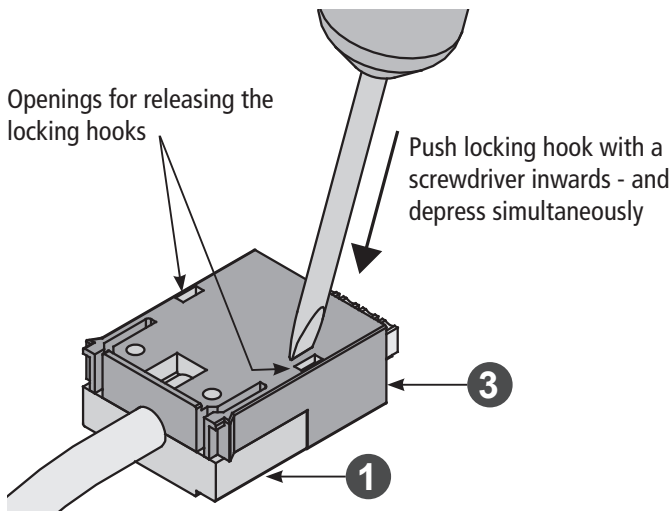

- Replace cable set - provided by the customer in place of connecting cable.
- Moung the housing cover ① with the both screws ②.

**NOTE**

Five terminals ④ to 1,5 mm<sup>2</sup>. The performances (especially the fire behavior) of locally provided cables, must be checked on own responsibility on compliance with the application-specific local regulations!

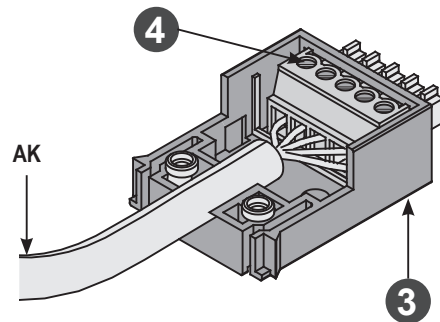

### Connection assignment

Function	Colour	DIN IEC 757	
OPEN / CLOSE	blue	BU	
OPEN / CLOSE	brown	BN	
Data	white	WH	
Rel: NO	violet	VT	
Rel: NO	green	GN	

M-COM® Click (Main control unit)	
<b>Order number:</b>	524167
<b>Application:</b>	Configuration module for the automatic configuration and monitoring of max. 4 opening and 2 locking drives type S12 / S3 in multi-drive systems.
<b>Rated voltage:</b>	24V DC (19 V ... 28 V)
<b>Current consumption:</b>	<12 mA
<b>Drive type:</b>	S12
<b>Protection class:</b>	IP30
<b>Ambient temperature:</b>	min. -5 °C ... + 70 °C
<b>Dimensions:</b>	40 x 26 x 15 mm
<b>Connection:</b>	for AUMÜLLER chain drives with <b>Wire Click</b>
<b>Equipment:</b>	Tongs for removing the M-COM® Click
<b>Feature / Equipment:</b>	able to configurate drive parameters by simple plug-on into the last drive of the multi-drive system. Suitable for 24V- or 230V-drives, but it can only be used on the 24V-side.

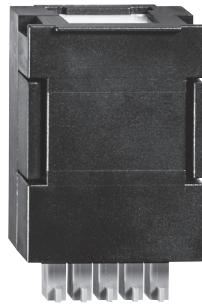

UniPC with configuration interface	
<b>Order number:</b>	524178
<b>Application:</b>	Hard- and software for configuration of drives supplied by AUMÜLLER GmbH.
<b>Rated voltage:</b>	24V DC +/-20%
<b>Parameterizable drives:</b>	24V DC type S3, S12 230V AC type S12
<b>Scope of delivery:</b>	software UniPC (Downloadlink*), Interface "ParInt", USB cable, connection cable * <a href="https://www.aumuller-gmbh.de/downloads">https://www.aumuller-gmbh.de/downloads</a>
<b>Features / Equipment:</b>	Power supply 24V DC is not included in the scope of delivery! Any extended settings require a software licence.



Any reconfiguration of a drive is entirely at the user's own risk and responsibility.

M-COM (Main control unit)	
<b>Order number:</b>	524177
<b>Application:</b>	Configuration module for the automatic configuration and monitoring of max. 4 opening and 2 locking drives type S12 / S3 in multi-drive systems.
<b>Rated voltage:</b>	24V DC (19 V ... 28 V)
<b>Current consumption:</b>	<12 mA
<b>Drive type:</b>	S12
<b>Protection class:</b>	IP30 rubber jacket
<b>Ambient temperature:</b>	0 °C ... + 70 °C
<b>Dimensions:</b>	45 x 17 x 6 mm
<b>Connecting wires:</b>	3 wires 0,5 mm <sup>2</sup> x 50 mm
<b>Feature / Equipment:</b>	printed circuit board with connecting wires for integration in site-supplied junction box.

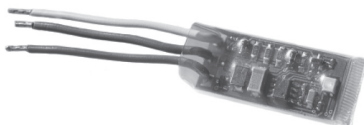

Wire Click	
<b>Order number:</b>	501251 - 3 m cable length - 24 V DC 501252 - 5 m cable length - 24 V DC 501253 - 10 m cable length - 24 V DC
<b>Application:</b>	Unitary plug-solution for AUMÜLLER Click Systems.
<b>Rated voltage:</b>	24V DC (19 V ... 28 V)
<b>Connecting cable:</b>	non-halogen, grey 5 x 0,5 mm <sup>2</sup>
<b>Terminal:</b>	to 1,5 mm <sup>2</sup>
<b>Feature / Equipment:</b>	<ul style="list-style-type: none"> <li>• Flexible cable length</li> <li>• Connect multiple drives in series connection</li> <li>• Torsion-plug</li> <li>• Locking hooks prevent withdrawal of the plug under tensile load</li> <li>• Strain relief according DIN EN 60335-1 by screwing the housing halves</li> </ul>



## Help in case of Malfunctions, Repairs and Maintenance

Professional repair of a defect drive can only be performed at the manufacturer's factory or manufacturer-certified specialist company. Unauthorized opening or manipulation of the drive terminates warranty.

1. Exchange defect drives or have them repaired by the manufacturer.
2. In case of problems during installation or normal operation the following table might be useful:

Problem	Possible causes	Possible solutions
<b>Drive does not start</b>	<ul style="list-style-type: none"> <li>• Duration of mains power supply too short</li> <li>• Drive run direction not correct</li> <li>• Connecting cable not connected</li> <li>• Power supply / Control Unit voltage incorrect, too high or too low (see data sheet)</li> <li>• No mains supply to power supply unit / Control Unit (no voltage)</li> <li>• Drive has shut down on overload</li> </ul>	<ul style="list-style-type: none"> <li>• Adjust supply voltage as specified in the technical documentation</li> <li>• Check drive cables</li> <li>• Check all connection cables</li> <li>• Check power supply unit and replace if necessary</li> <li>• Connect power supply</li> <li>• First move drive in CLOSE position</li> </ul>
<b>Drive doesn't start after having been in operation several times</b>	<ul style="list-style-type: none"> <li>• Operating time has been exceeded, drive has been overheated</li> <li>• See possible solutions above associated with „Drive doesn't start“</li> </ul>	<ul style="list-style-type: none"> <li>• Wait until drive has cooled down and start again</li> <li>• See possible solutions associated with: “Drive doesn't start“</li> </ul>
<b>Drive doesn't close</b>	<ul style="list-style-type: none"> <li>• Closing edge safety mechanism has been triggered (if existing)</li> <li>• See possible solutions above associated with „Drive doesn't start“</li> </ul>	<ul style="list-style-type: none"> <li>• Release safety area for operation and reset closing edge safety mechanism</li> <li>• See possible solutions associated with: “Drive doesn't start“</li> </ul>
<b>Drive travels uncontrolled in open and close direction</b>	<ul style="list-style-type: none"> <li>• Residual ripple of power supply / control unit too high</li> <li>• Fault in power supply unit / control unit</li> </ul>	<ul style="list-style-type: none"> <li>• Adjust drive voltage to the required value of drive. (values see data sheet of drive)</li> <li>• Check output voltage of power supply unit or control unit</li> </ul>
<b>Drive closes, but after about 10 mm the drive open</b>	<ul style="list-style-type: none"> <li>• Close the window outside the 40 mm (Soft run mode).</li> </ul>	<ul style="list-style-type: none"> <li>• Drive mounted so, that the closing process takes place within the 40 mm (e.g. use spacer under the casement bracket).</li> </ul>

## Maintenance and Modification

To ensure continuous function and safety of the drive periodic maintenance by a specialist company is required at least once a year (as mandated by law and recommended by manufacturer). Operational readiness must be checked regularly. Frequent inspection of the system for imbalance and signs of wear or damages of cables and fastening elements must be performed.

During maintenance contaminations must be removed from the drive. Fastenings and clamping screws must be checked for tightness. Test runs during the opening and closing procedure of the devices must be performed.

The drive itself is maintenance-free. Defect devices may only be repaired in our factory. Only spare parts of the manufacturer may be used. When the connection cable of this device is damaged it must be replaced by the manufacturer or his customer service or a similarly qualified person to avoid endangerment.

It is recommended to conclude a maintenance contract. A sample maintenance contract can be downloaded from the homepage of

**Firm AUMÜLLER AUTOMATIC GmbH**  
([www.aumueller-gmbh.de](http://www.aumueller-gmbh.de)).

While cleaning the windows, drives may not have direct contact with water or cleaning agents. Drives must be protected from dirt and dust during the construction phase or renovations.

### Maintenance process

1. Open or extend power-operated casement completely.
2. Completely disconnect the system from the mains and secure it against automatic or manual activation.
3. Check windows and fittings for damages.
4. Check all mechanical fastenings (if required, observe information on torques in installation instructions).
5. Check electric drives for damages and contaminations.
6. Check connecting cables (drive cable) for:
  - tightness of the cable screw
  - functionality of the strain relief
  - damages
7. Check the mobility of hinges and fittings and re-adjust or apply lubricant, e.g. silicone spray (observe the instructions of the manufacturer of this window system).
8. Check peripheral seal, remove contaminations or replace.
9. Perform cleaning to maintain functionality (e.g. clean extending elements of the drive, such as chains or spindles by damp wiping them with acid or lye-free agents and drying them and, if required, lubricate them with cleansing oil e.g., Ballistol).
10. Turn on operating voltage.
11. Open and close the power-operated window via the operating voltage (functional test).
12. If available, check and re-adjust protection systems of the safe guard fixture.
13. Check the intactness of the CE label at the power-operated system.
14. Check the intactness of warning instructions and labels at the respective drive.
15. Perform a risk assessment in accordance with Machinery Directive 2006 / 42 / EG, if required, e.g. after modifying the machine.

## Demounting

The drives are demounted by reversing the steps, as for the installation. The adjustments are omitted.

1. Completely disconnect the system from the power supply before demounting a drive.
2. After demounting a drive the window must be secured against independent opening.

Dispose of parts according to the locally applicable legal provisions.

## Disposal

The symbol of the „crossed-out dustbin“ means that you are legally obliged to collect these appliances separately and recycle them in an environmentally friendly manner. Do not throw old electrical appliances into the household waste! Information on return options can be found at:

<https://www.aumueller-gmbh.de/umweltschutz>

Before disposing of old electronic devices, please delete all personal data stored on them, if available. Remove any device batteries or rechargeable batteries and put them in the old battery collection. Tape the poles beforehand to avoid a short circuit.

Dispose of the shipping and transport material, separated according to material, in the appropriate recycling bin.



## Liability

We reserve the right to change or discontinue products at any time without prior notice. Illustrations are subject to change. Although we take every care to ensure accuracy, we cannot accept liability for the content of this document.

## Warranty and Customer Service

In principal apply our:

„General Terms for the Supply of Products and Services of the German Electrical Industry (ZVEI)“.

The warranty corresponds with legal provisions and applies to the country in which the product has been acquired.

The warranty includes material and manufacturing defects incurred during normal use.

The warranty period for delivered material is twelve months.

Warranty and liability claims for personal injuries or material damages are excluded, if caused by one or more of the following:

- No proper incoming goods inspection.
- Improper use of the product.
- Improper installation, commissioning, operation, maintenance or repair of the product.
- Operating the product by defect and improper installed or not functioning safety and protection devices.
- Ignoring instructions and installation requirements in these instructions.
- Unauthorized constructional modifications at the product or accessories.
- Disaster situations due to effects of foreign bodies and Acts of God.
- Wear and tear.

Contact persons for possible warranty claims, for spare parts or accessories are the employees of the responsible branch office or the responsible person at

**Firm AUMÜLLER AUMATIC GmbH.**

Contact data are available at our homepage

**([www.aumueller-gmbh.de](http://www.aumueller-gmbh.de))**

## Certificate and Declaration of Conformity

We declare under our sole responsibility that the product described under "Data sheet" is in conformity with the following directives:

- 2014/30/EU  
Directive relating to Electro-Magnetic Compatibility
- 2014/35/EU  
Low voltage Directive



We further declare that the drive is an incomplete machine within the meaning of the European Machinery Directive (2006/45/EG).

Technical file and declaration at firm:

**AUMÜLLER AUMATIC GmbH**  
Gemeindewald 11  
D-86672 Thierhaupten

Ramona Meinzer  
Managing Director (Chairman)

### Note:

The proof of the application of a quality management system is for company:

**AUMÜLLER AUMATIC GmbH**  
according to the certification basis **DIN EN 9001** as well the "Declaration of Incorporation and Conformity" can be accessed via the QR code or directly on our homepage:  
([www.aumueller-gmbh.de](http://www.aumueller-gmbh.de))



### Translation of the original instructions (German)

#### Important note:

We are aware of our responsibility, which is why we present life-supporting and value-preserving products with greatest possible conscientiousness. Although we make every effort to ensure that the data and information are as correct and up-to-date as possible, we still cannot guarantee that they are free from mistakes and errors.

All information and data contained in this document are subject to alterations without prior notice. Distribution and reproduction of this document as well as the use and disclosure of its content is not authorized unless expressly approved. Offenders will be held liable for the payment of damages. All rights reserved in the case of a patent award or utility model registration.

Basically the General Terms and Conditions of **AUMÜLLER AUTOMATIC GmbH** apply to all offers, supplies and services.

The publication of these assembly and commissioning instructions supersedes all previous editions.

AUMÜLLER AUMATIC GMBH  
Gemeindewald 11  
86672 Thierhaupten

Tel. +49 8271 8185-0  
Fax +49 8271 8185-250  
info@aumueller-gmbh.de

[www.aumueller-gmbh.de](http://www.aumueller-gmbh.de)